

**Italiano** 2011-2012

*Teo Lehtimäki Oy*



**Teo Lehtimäki Oy è il Distributore di:**  
Camoplast Inc.



PPD Group



CV Tech-IBC



Wahl Bros  
Racing

Updated 04.03.2012

Benvenuti sulle pagine Web dell' Azienda Teo Lehtimaki Oy

L'Azienda Teo Lehtimaki Oy è una azienda familiare, nata nel 1991.

Vendiamo pezzi di ricambio per le motoslitte. Esportiamo anche i nostri prodotti fuori Finlandia, principalmente negli altri paesi Nordici, nelle Alpi Europee, Estonia e Russia.

Noi importiamo pezzi di ricambio dai produttori di prima scelta come Camoplast, CV-Tech, IBC Canada, PPD Industries, Wahlbros Racing e Garland.

La nostra azienda è flessibile e consegna velocemente. Abbiamo una vasta conoscenza di tutti ricambi dal settore della fabbricazione delle motoslitte sino alla messa sul mercato. Le nostre pagine danno anche aiuti tecnici, istruzioni di installazione e raccomandazioni su come usare i pezzi di ricambi. Vengono aggiornate regolarmente, per incoraggiare Voi a visitarle più spesso.

# Catalogo 2010-2011

Nel catalogo, fabbricazioni originali con il loro codice per identificarle correttamente  
. Il nostro prodotto di ricambio può essere diversa fabbricazione.

## Teo Lehtimäki Oy

Kaarronnevantie 54 61800 Kauhajoki Finland

Vesa Peltonen

mob. +358-40-5769111 Vesa Peltonen

fax +358-6-2311170

info@teolehtimaki.fi

vat. FI08350750

## Teo Lehtimäki Oy

Vuopajantie 34 96400 Rovaniemi Finland

Artturi Lehtimäki

mob. +358-400-162110 Artturi Lehtimäki

fax +358-16-366004

### Personal e-mails

vesa@teolehtimaki.fi

Vesa Peltonen

artturi@teolehtimaki.fi

Artturi Lehtimäki

teo@teolehtimaki.fi

Teo Lehtimäki

### Financial questions

Vesa Peltonen

vesa@teolehtimaki.fi

[www.teolehtimaki.fi](http://www.teolehtimaki.fi)

## Content

- 3- 4 **Finn made tracks**
- 5-13 **Camoplast tracks**
- 14-16 **Extensions, cleats**
- 17-18 **Sprockets**
- 19-19 **Wheels**
- 20-21 **Slides**
- 22-23 **Springs, pawl kits**
- 24-24 **Shafts, Hood clamps**
- 25-25 **Syncro sprockets**
- 26-26 **Bearings, tie rod ends**
- 27-27 **Fuel pump, hooks**
- 28-31 **Ski skins**
- 32-37 **Carbide runners**
- 38-44 **Clutch, driven**
- 45-48 **Crankshaft bearings**
- 49-49 **Carburetor flanges**
- 50-51 **Engine gaskets**
- 52-58 **Pistons**
- 59-59 **Wind shields**
- 60-61 **Brake pads,**
- 62-63 **Chains, sprocket**
- 64-67 **CDI, ign. coils**
- 68-68 **Starter engines**



Driven pulley, see page 44  
A lot of new models.



**01-100 Charger 12 V**

## Note.

This page and 2000 more like this one:  
[www.teolehtimaki.fi/spare parts catalogue](http://www.teolehtimaki.fi/spare_parts_catalogue)  
and pls, check your make.

**Malli:** MXZ 583

**Vuosi:**

**1996**

**Skidoo**

### Moottori

#### Rotax 583 96-

09-772	mäntä, std
09-772-01	mäntä, 0,25 ylikoko
09-772-02	mäntä, 0,50 ylikoko
09-772-03	mäntä, 0,75 ylikoko
09-772-04	mäntä, 1,00 ylikoko
35-505	männäntapin laakeri
710-214	tiivistesarja, prof
09-167	kampiakselin tiiviste
09-165	kampiakselin tiiviste
09-16002	välitiiviste kampiakseli
35-6206NR	kampiakselin laakeri
35-6207NR	kampiakselin laakeri
35-6305	kampiakselin laakeri
01-158	käynnistimen jousi
01-154	käynn. korjaussarja



Omistaja: **Teo Lehtimäki**, myyty

Kuvassa **Tommi ja Lotta**

**38**

**307 / 22**

**04-9793, 04-9009,  
04-9830, 04-9753**

### Telamatto, leveys cm, pituus cm ,



<b>30-21</b>	<b>L=140 cm musta</b>
<b>30-621</b>	<b>L=140 cm grafiitti</b>
<b>30-210</b>	<b>L=163 cm musta</b>
<b>30-321</b>	<b>L=140 cm keltainen</b>

**3700-3800** r/min, kytkentäkierrosluku  
**7900-8000** r/min, max. kierrosluku

### Voimansiirto / Teo Lehtimäki Oy

#### P50- korvaa alkuperäisen



**15-19 ( 0019 )**  
**Kal: 7009**  
**Jousi: 0451-1118**  
**Jousi: 15-54**  
**Shims: 5 + 1**

### Sähköosat

**05-B8** sytytystulppa  
**01-14342** CDI yksikkö  
**01-15416** tasasuuntaaja, E-mallit  
**01-15415** jännitteensäädin  
**01-14355** puola

### Muut osat / Teo Lehtimäki Oy

**These pages  
are updated  
frequently.**

### Sukset

#### Peltisuksi

**32-99** Suksimuovi  
**33-20** CTRL levike 180 mm  
**MM142** Kovametalli



Width 38 and 50 cm



**04-6000**

**HSB 54**

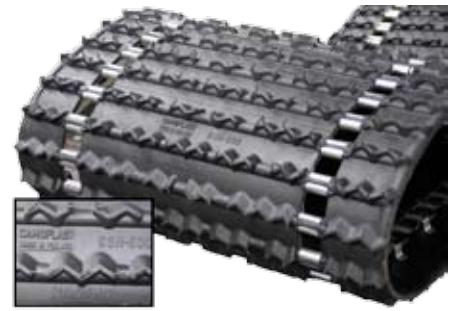

Width 60 cm

**Lynx 20, Lynx 30**

**04-2450** 38 x 245 cm B = 48 pcs

**04-9755 USA** 38 x 290 cm B = 58 pcs

**Ockelbo**

**Lynx 320 and 330 makes**

**04-3375** 38 x 375 cm B = 75 pcs

**04-3377** 38 x 385 cm B = 77 pcs

**Lynx 535**

**Winha**

**04-5370** 50 x 372 cm B = 74 pcs

**Trapper 500**

**Nordik 500, 540, 500PSS, 550**

**04-5372** 50 x 372 cm B = 74 pcs

**04-5382** 50 x 382 cm B = 76 pcs

**Nordik 600 SL / SLE**

**04-6370** 60 x 372 cm B = 74 pcs

**Ockelbo 600 04-6000**

**Only the tracks above in inventory, september 2011.**

We ask that you tell your customers the track manufacturing in Finland has ceased in the summer of 2010. We do not have these tracks longer and we are also not allowed to get. The only way is to change the track and put in there inside-driven track. It is possible, but requires special measures. See the next page....

Snowmobile production at Camoplast facility located in Tampere, Finland is being transferred and phased out. Snowmobile production for current production snowmobiles is being transferred to Plattsburgh, NY USA. For snowmobile tracks produced from flat press tooling for aftermarket service parts, production will be phased out.

### Lynx 5900 how to replace a new model track

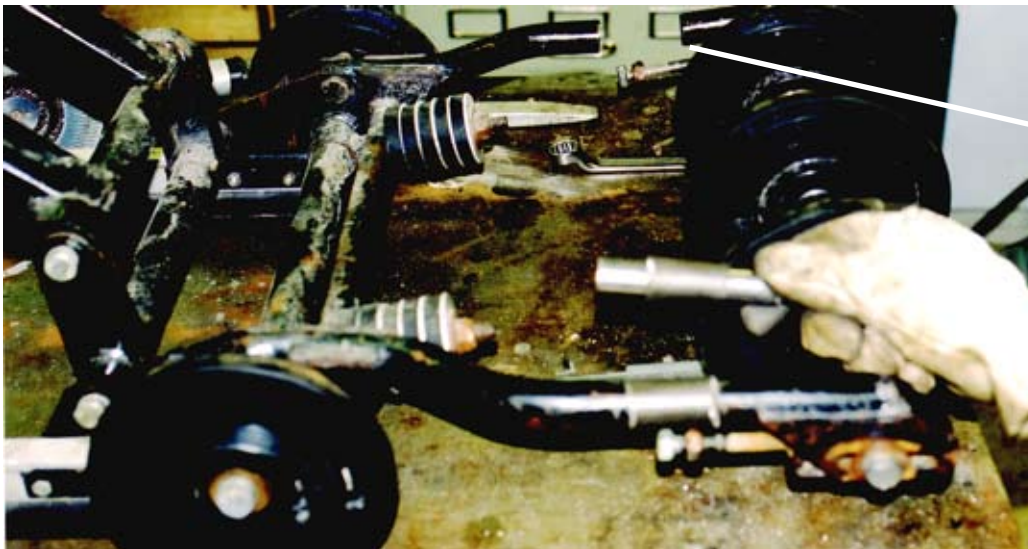

Cut the tubes

Weld the piece of tube between the tubes you cut.

The pieces are delivered with the track.

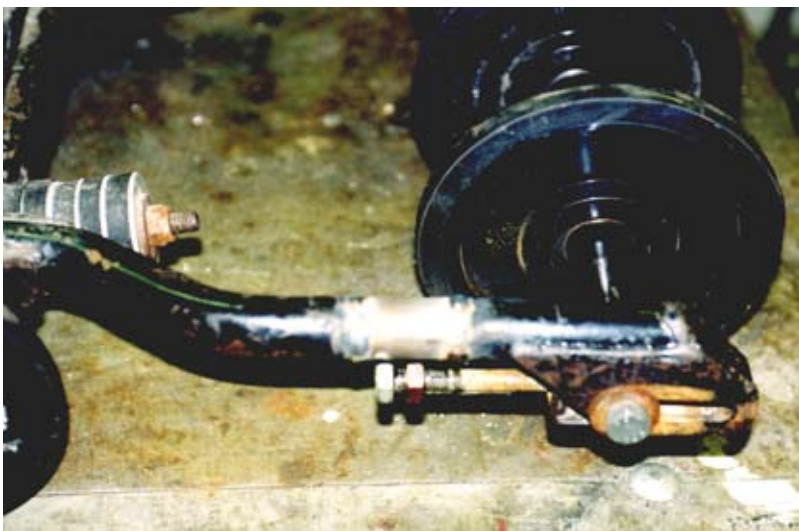

The weld has been done  
This snowmobile has round rear wheels. You can replace also rear sprockets, if they exist.

You must replace also drive sprocket. It is only possible if there is a hexa drive shaft.

**We prefer to use No Slip wheels**

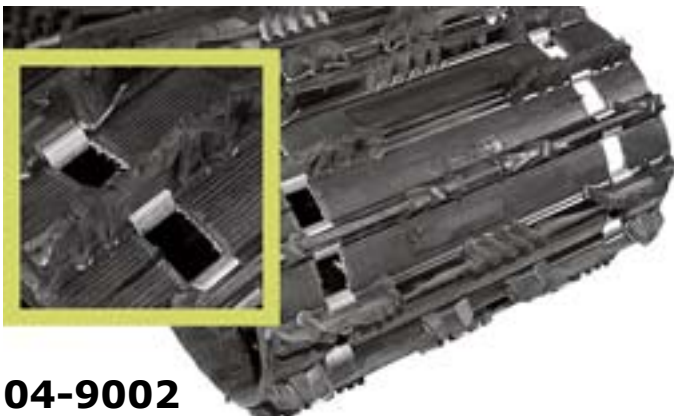

**04-9002**



**Sokosti**

**04-9005**

# Utility

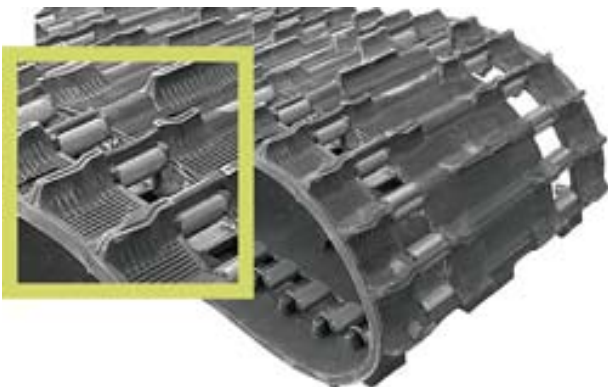
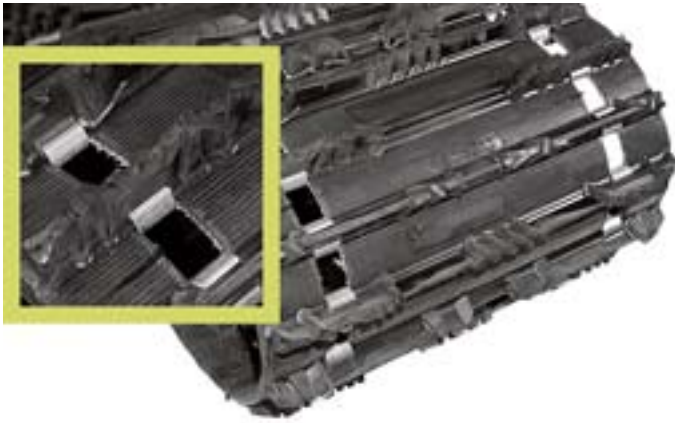

Rip Saw Full clip Pitch 2,52"			
Number	width	length	cam
	cm	cm	mm
04-9002	50	396	32

Rip Saw Full clip Pitch 2,86"			
Number	width	length	cam
	cm	cm	mm
04-9089	50	392	38

## New

Cobra Full clip Pitch 2,86"			
Number	width	length	cam
	cm	cm	mm
04-9195	50	392	44
04-9196	50	392	38

Ice Tech			
Number	width	length	cam
	cm	cm	mm
04-9008	50	396	32

Bearcat, Scandik WT. Lynx, Polaris, Yamaha Viking

Explorer 25 mm Full clip			
Number	width	length	cam
	cm	cm	mm
04-9806	38	396	25

Explorer 19 mm full clip			
Number	width	length	cam
	cm	cm	mm
04-9011	38	353	19

## Cam 19 mm, Elan, Safari, Lynx, Old models



<b>Durasport 15 mm full clip</b>			
<b>Number</b>	<b>width</b>	<b>length</b>	<b>cam</b>
	<b>cm</b>	<b>cm</b>	<b>mm</b>
<b>04-9755</b>	<b>38</b>	<b>290</b>	<b>15</b>
<b>wheel boggie</b>			
<b>04-9756</b>	<b>38</b>	<b>290</b>	<b>15</b>
<b>slide suspension</b>			

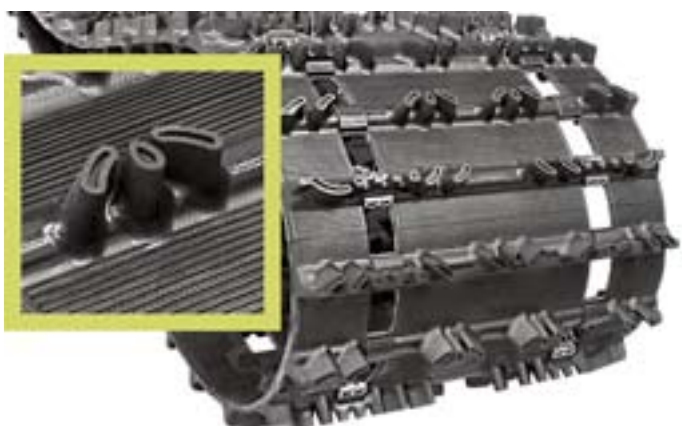

<b>Hack Saw 25 mm full clip</b>			
<b>Number</b>	<b>width</b>	<b>length</b>	<b>cam</b>
	<b>cm</b>	<b>cm</b>	<b>mm</b>
<b>04-9009</b>	<b>38</b>	<b>307</b>	<b>25</b>
<b>04-9010</b>	<b>38</b>	<b>345</b>	<b>25</b>

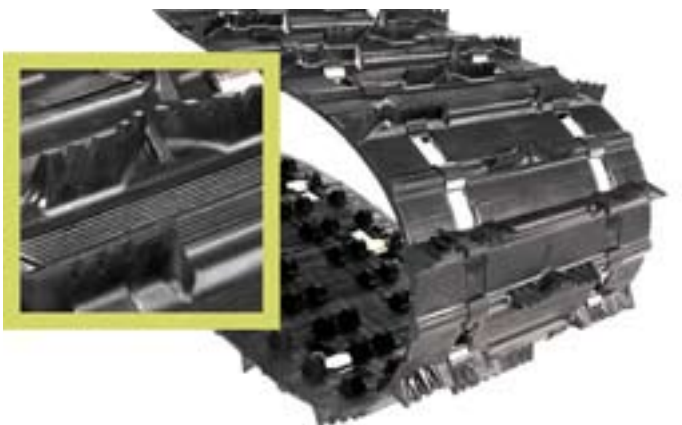

<b>Challenger 25 mm 2/1 cleat</b>			
<b>Number</b>	<b>width</b>	<b>length</b>	<b>cam</b>
	<b>cm</b>	<b>cm</b>	<b>mm</b>
<b>04-9793</b>	<b>38</b>	<b>307</b>	<b>25</b>
<b>04-9794</b>	<b>38</b>	<b>345</b>	<b>25</b>



<b>Durasport 25 mm full clip</b>			
<b>Number</b>	<b>width</b>	<b>length</b>	<b>cam</b>
	<b>cm</b>	<b>cm</b>	<b>mm</b>
<b>04-9753</b>	<b>38</b>	<b>307</b>	<b>25</b>
<b>04-9863</b>	<b>38</b>	<b>345</b>	<b>25</b>

## Special tracks



### Yamaha, Polaris

Free ride 38 mm full clip			
Number	width	length	cam
	cm	cm	mm
<b>04-9033</b>	<b>36</b>	<b>307</b>	<b>38</b>
<b>04-9034</b>	<b>36</b>	<b>345</b>	<b>38</b>
<b>04-9044</b>	<b>36</b>	<b>365</b>	<b>38</b>



### Arctic Cat

Hack Saw 25 mm full clip			
Number	width	length	cam
	cm	cm	mm
<b>04-9960</b>	<b>34,3</b>	<b>325</b>	<b>25</b>

**New  
XC Pro**

**Pitch 2,86"**



XC Pro 44 mm full clip			
Number	width	length	cam
	cm	cm	mm
<b>04-9169</b>	<b>38</b>	<b>305</b>	<b>44</b>
<b>04-9189</b>	<b>38</b>	<b>348</b>	<b>44</b>



## Rip Saw profiles



**Pitch 2,52"**

### Rip Saw 32 mm

Rip Saw 32 mm			
Number	width	length	cam
	cm	cm	mm
04-9146	38	307	32
04-9040	38	325	32
04-9922	38	345	32
04-9006	38	365	32
04-9007	38	385	32
04-9925	38	403	32
Special width			
04-9021	40,5	345	32
Pitch 2,86"			
04-9049	38	305	32
04-9080	38	348	32
cleat	full clip		
cleat	every 3 rd, open		
cleat	every 3 rd, closed		

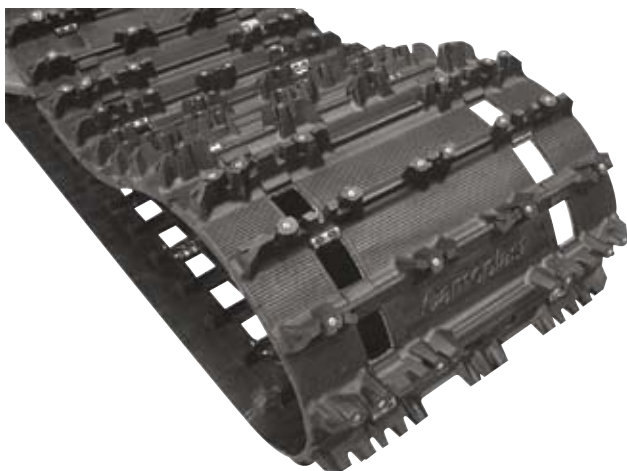

### Ice Ripper, jako 2,52"

Ice Ripper 32 mm cleat 2/1			
Number	width	length	cam
	cm	cm	mm
04-9077	38	307	32
04-9079	38	345	32

### Ice Ripper , pitch 2,86"

Ice Ripper 32 mm full clip			
Number	width	length	cam
	cm	cm	mm
04-9190	38	305	32
04-9191	38	348	32

### Rip Saw 38 mm



Rip Saw 38 mm full clip			
Number	width	length	cam
	cm	cm	mm
04-9112	38	307	38
04-9045	38	325	38
04-9113	38	345	38
cleat	every 3 rd, open		



Cobra 34 mm fullclip pitch 2,52			
Number	width	length	cam
	cm	cm	mm
04-9052	38	307	34
04-9081	38	325	34
04-9061	38	345	34

Cobra 34 mm fullclip pitch 2,86			
Number	width	length	cam
	cm	cm	mm
04-9092	38	305	34
04-9093	38	348	34
04-9094	38	370	34



Sokosti 38 mm full clip			
Number	width	length	cam
	cm	cm	mm
04-9003	38	365	38
04-9004	38	384	38
04-9005	38	403	38
cleat	every 3 rd, open		

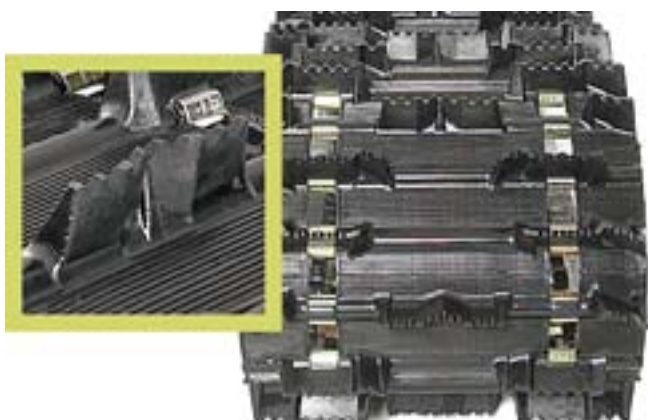

Intense 38 mm full clip			
Number	width	length	cam
	cm	cm	mm
04-9930	38	307	38
<b>Note:</b> not soft compound			
04-9108	38	345	38

**Pitch 2,86"**



Rip Saw 44 mm full clip			
Number	width	length	cam
	cm	cm	mm
04-9159	38	305	38
04-9076	38	348	38
04-9139	38	305	44
04-9096	38	348	44
04-9121	38	370	44

**Back Country pitch 2,52" New design and new rubber compound**



<b>Back Country 44 mm full clip</b>			
<b>Number</b>	<b>width</b>	<b>length</b>	<b>cam</b>
	<b>cm</b>	<b>cm</b>	<b>mm</b>
<b>04-9140</b>	<b>38</b>	<b>307</b>	<b>44</b>
<b>04-9141</b>	<b>38</b>	<b>325</b>	<b>44</b>
<b>04-9142</b>	<b>38</b>	<b>345</b>	<b>44</b>
<b>04-9143</b>	<b>38</b>	<b>365</b>	<b>44</b>

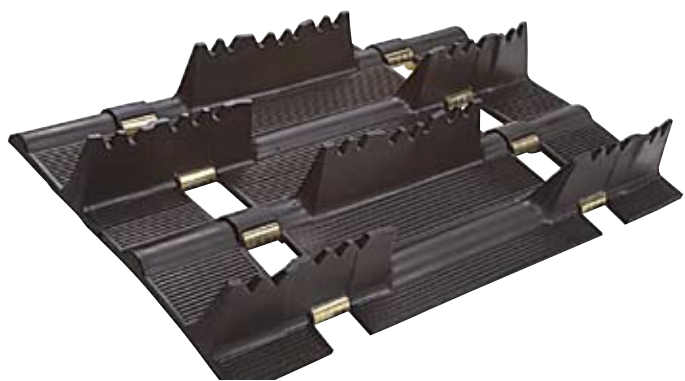

**Pitch 2,86"**

<b>Challenger 44 mm full clip</b>			
<b>Number</b>	<b>width</b>	<b>length</b>	<b>cam</b>
	<b>cm</b>	<b>cm</b>	<b>mm</b>
<b>04-9069</b>	<b>40,5</b>	<b>305</b>	<b>44</b>
<b>04-9070</b>	<b>40,5</b>	<b>348</b>	<b>44</b>
<b>04-9167</b>	<b>40,5</b>	<b>370</b>	<b>44</b>
<b>04-9186</b>	<b>40,5</b>	<b>348</b>	<b>44</b>
<b>04-9187</b>	<b>40,5</b>	<b>370</b>	<b>44</b>
<b>04-9187</b>	<b>40,5</b>	<b>392</b>	<b>44</b>

**Pitch 2,86"**



<b>Back Country X 44 mm full clip</b>			
<b>Number</b>	<b>width</b>	<b>length</b>	<b>cam</b>
	<b>cm</b>	<b>cm</b>	<b>mm</b>
<b>04-9128</b>	<b>38</b>	<b>305</b>	<b>44</b>

**Pitch 2,86"**

**New**

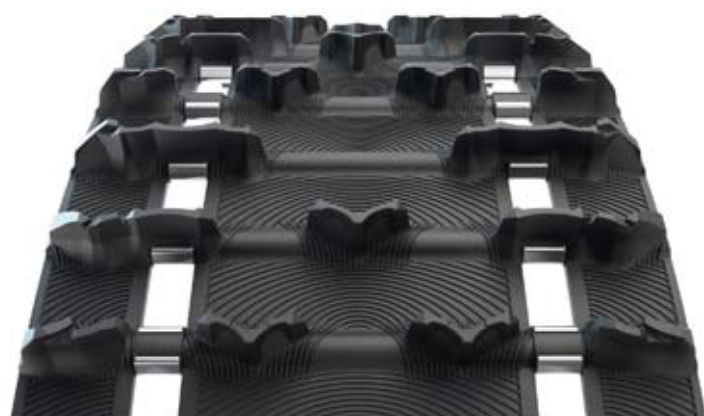

<b>Rip Saw II 38 mm full clip</b>			
<b>Number</b>	<b>width</b>	<b>length</b>	<b>cam</b>
	<b>cm</b>	<b>cm</b>	<b>mm</b>
<b>04-9156</b>	<b>38</b>	<b>305</b>	<b>38</b>

## Pitch 2,86"

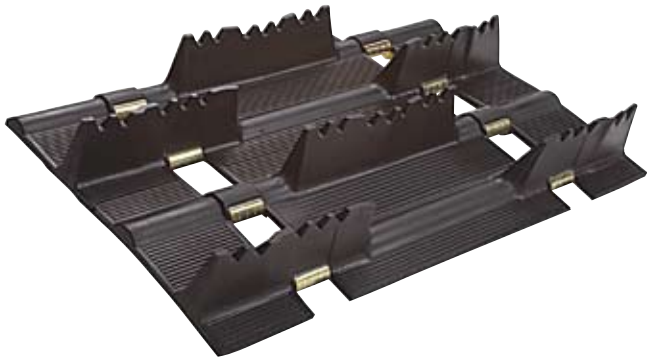

Challenger 51 mm full clip			
Number	width	length	cam
	cm	cm	mm
04-9086	38	348	51
04-9087	38	370	51
04-9088	38	391	51

## Pitch 2,86"



Challenger 63 mm full clip			
Number	width	length	cam
	cm	cm	mm
04-9102	40,5	394	63
04-9103	40,5	414	63
04-9103	38	394	63

## Challenger 51 mm full clip

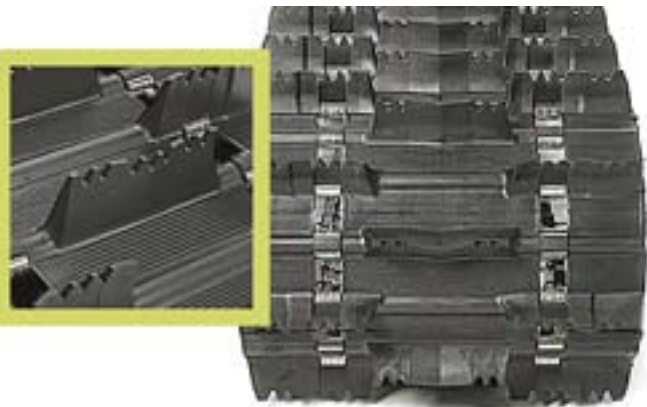

Challenger 51 mm full clip			
Number	width	length	cam
	cm	cm	mm
04-9798	38	307	51
04-9797	38	345	51
04-9875	38	365	51
04-9876	38	384	51
04-9884	38	403	51
04-9899	40,5	365	51
04-9919	40,5	384	51
04-9941	40,5	403	57

## Pitch 2,52"



Challenger 44 mm full clip			
Number	width	length	cam
	cm	cm	mm
04-9933	40,5	345	44

## Pitch 3,00"



Challenger 57 mm full clip			
Number	width	length	cam
	cm	cm	mm
04-9984	38	358	57

Challenger 63 mm full clip			
Number	width	length	cam
	cm	cm	mm
04-9942	38	365	63
04-9174	38	388	63
04-9175	38	411	63
04-9176	40,5	411	63



## Pitch 2,86"

Challenger Ext 63 mm full clip			
Number	width	length	cam
	cm	cm	mm
04-9144	40,5	371	63
04-9145	38	371	63

Challenger Ext 57 mm full clip			
Number	width	length	cam
	cm	cm	mm
04-9064	40,5	371	57
04-9065	40,5	391	57
04-9066	40,5	414	57

## Peak 2,5 New

## Pitch 2,86"



Peak 2,5 63 mm full clip			
Number	width	length	cam
	cm	cm	mm
04-9182	38	370	63
04-9181	38	391	63
04-9180	38	414	63
04-9179	40	370	63
04-9178	40	391	63
04-9177	40	414	63

# Extendings

**04-3050**  
universal 12 cm



**04-3080**  
Yamaha 20 cm



**04-3040**  
universal 25 mm shaft  
20 cm



**04-3060**  
Yamaha 12 cm



**04-3300**  
Lynx 20 cm

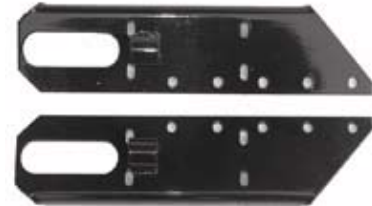

**04-3070**  
To shorten Lynx G-type.  
320 cm long boggie made  
use track 307 cm long

**04-3000**



# Aluminium profiles



## 04-3001

chassie 400-420 mm  
length 600 mm

## 04-3003

chassie 415-430 mm  
length 600 mm

By using this profile, the chassie can be extended by max. 400 mm. Note, that you cannot attach a tow hook on this profile without appropriate brackets.



## 04-3002

chassie 400-410 mm  
length 200 mm

By using this profile, the chassie can be extended by max. 150 mm.

### Cleat

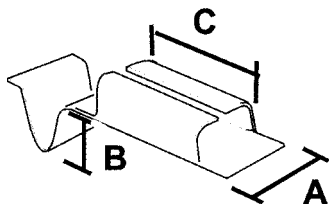

p/n	A	B	C
38-01	18	-	30
38-02	21	-	30
38-03	20	16	30
38-04	23	18	21
38-05	21	-	38
38-07	21	-	19
38-08	22	-	20
38-09	19	14	25
38-10	19	-	25
38-11	19	16	37

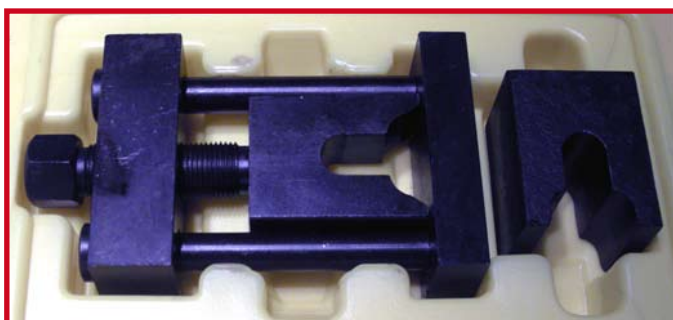
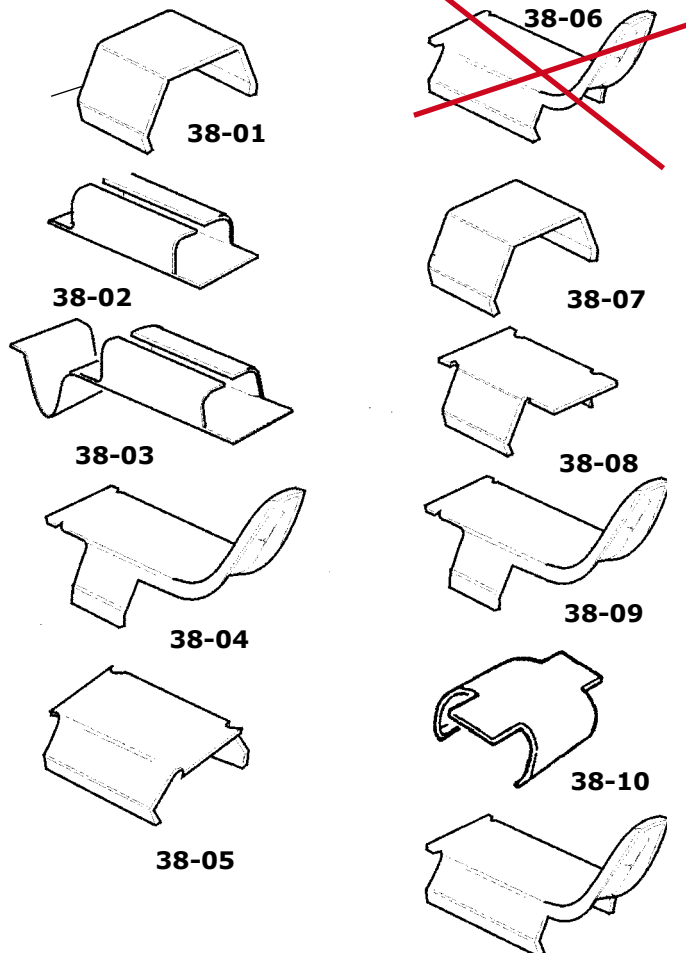

Track clip tool, bolt type  
It will fit the 1 1/2" clips and also the 1" clips with narrow insert

**Part number: 38-100**

# 04-9925 + 04-3000 = 403 cm

This old 345 cm track can be replaced with 403 cm Predator as shown on the picture below. Boggie has been extended, 180 mm idler wheels at the rear. 04-3000 extension kit will be delivered with all needed parts except screws and rivets.



**365 cm**



**384 cm**



## Lynx

**04-9040 38 x 325 cm**



Orig. track 320 cm  
or 330 cm long

Adjustment is long  
enough



**No Slip sprockets,**

**patent by Wahl Bros.**



21-08PO

Number	Tooth	Pitch	Outer dia	Shaft / mm	Bore
39-00	7	2,52"	136 mm	25,0-27,0	24,0 mm
39-01	7	2,52"	136 mm	27,0-29,0	26,0 mm
39-02	7	2,52"	136 mm	32,0-34,0	31,0 mm
39-05	8	2,52"	158 mm	25,0-27,0	24,0 mm
39-06	8	2,52"	158 mm	32,0-34,0	31,0 mm
39-08	8	2,52"	158 mm	27,0-29,0	26,0 mm
39-09	9	2,52"	177 mm	27,0-29,0	26,0 mm
39-10	10	2,52"	197 mm	27,0-29,0	26,0 mm
39-15	7	2,86"	155 mm	25,0-27,0	24,0 mm
39-16	7	2,86"	155 mm	32,0-34,0	31,0 mm
39-17	7	2,86"	155 mm	27,0-29,0	26,0 mm
39-18	8	2,86"	181 mm	27,0-29,0	26,0 mm
39-26	7	3,00"	163 mm	32,0-34,0	31,0 mm
39-27	7	3,00"	163 mm	27,0-29,0	26,0 mm
39-28	8	3,00"	190 mm	27,0-29,0	26,0 mm
39-42	7	2,86"	155 mm	Tube shaft	Skidoo, Lynx
39-43	8	3,00"	190 mm	Tube shaft	Skidoo, Lynx
21-08PO	8	3,00"	190 mm	Tube shaft	Polaris

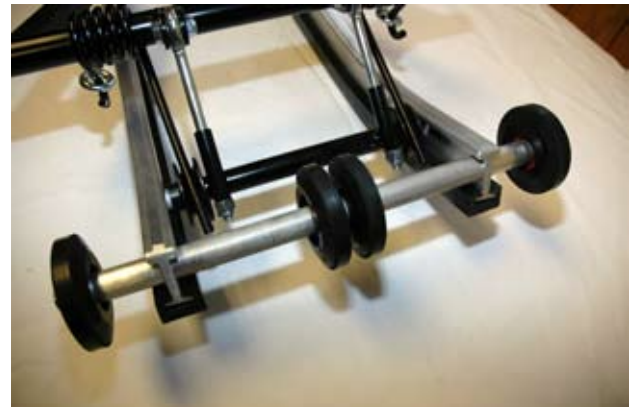

### Anti-Stab wheel kit

Stab wheel kit help to prevent track spearing by preventing the track from coming into contact with the tips of the suspension rails.

- 39-791 Center, 223 mm shaft  
Arctic Cat, Yamaha
- 39-793 Center, 220 mm shaft  
Skidoo, Polaris, Lynx

# Sprockets

Number	Tooth	Pitch	Bearing	Note
20-5285	9	50 mm	35-6205	Ockelbo, width 25 mm
20-5286	9	50 mm	35-6205	Ockelbo, Trapper, width 30
20-5287	11	50 mm	35-6205	Lynx, Nordik 300
20-5288	10	50 mm	35-6205	Nordik PSS, 540, 550
20-5289	9	2,52"	35-6205	track 9806, 9925, 9005
37-00	9	50 mm	-	Sprocket, width 22 mm
37-01	9	50 mm	-	Sprocket, width 30 mm
37-03	11	50 mm	-	Sprocket, width 30 mm
37-04	11	50 mm	hexa 27mm	Sprocket, width 30 mm
37-06	-	-	-	For wheel suspens 127 mm



37-03



37-04



20-5285, 20-5286



20-5287



20-5288



20-5289

## Sprockets



Number	Tooth	Pitch	External	Shaft / mm	Hexa
21-07N	7	2,52"	136 mm	Square	Square 21,0
21-07K	7	2,52"	136 mm	25,0-27,0	24,0 mm
21-07G	7	2,52"	136 mm	27,0-30,0	26,0 mm
21-08AC	8	2,52"	158 mm	25,0-28,0	24,0 mm
21-08LY	8	2,52"	158 mm	32,0-34,0	31,0 mm
21-09PO	9	2,52"	177 mm	25,0-28,0	24,0 mm
21-09LY	9	2,52"	177 mm	32,0-34,0	31,0 mm

# Idler wheels

Number	Diameter	Bearing	Colour	Fit
20-82	082	35-620258	black	
20-108	108	35-620258	black	Skidoo, Lynx, Polaris
20-117	117	35-6205	black	Polaris
20-127	127	35-620258	black	Lynx
20-130	130	35-6004	black	Yamaha
20-133	133	35-6004	black	Lynx, Ockelbo
20-135	135	35-6205	silver	Skidoo, Trapper, Nordik
20-135F	135	35-6205	silver	Full moon, Skidoo
20-5350	135	35-6205	silver	Polaris, inserts..
20-5630	143	35-6205	black	Arctic Cat
20-5630H	143	35-6205	silver	Arctic Cat
20-5630G	143	35-6205	green	Arctic Cat
20-155	155	35-6205	black	Skidoo, Trapper, Nordik
20-6380H	160	35-6205	silver	Polaris, Arctic Cat
20-6375S	160	35-6205	blue	Polaris, Arctic Cat
20-6375P	160	35-6205	red	Polaris, Arctic Cat
20-165K	165	35-6205	yellow	Lynx
20-165P	165	35-6205	red	Lynx
20-165H	165	35-6205	silver	Lynx
20-180	180	35-6205	silver	Lynx, 04-3000 flip
20-131	180	35-6204	black	Yamaha
20-200	200	35-6205	black	kaikki



## Inserts

20-34 insert 3/4 " pair

20-58 insert 5/8 " pair



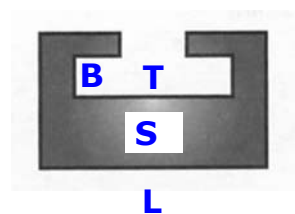
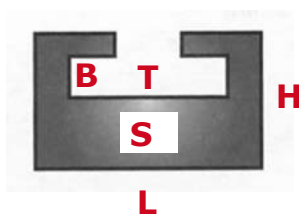

# Runner shoe

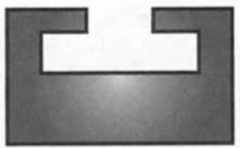

Arctic Cat	Width L mm		height H	thickn S	B ,mm	T ,mm
	<b>30</b>		<b>20</b>	<b>9,5</b>	<b>5</b>	<b>19</b>
	Number	length cm	color	Arctic Cat, all models after -78		
	<b>30-10</b>	140	black			
	<b>30-610</b>	140	graphit			
	<b>30-410</b>	163	orange			
	<b>30-167</b>	167	black	Arctic Cat, Super Jag, Karibo		

Skidoo, Lynx	Width L mm		height H	thickn S	B ,mm	T ,mm
	<b>37,5</b>		<b>19</b>	<b>10</b>	<b>5</b>	<b>26</b>
	Number	length cm	color			
	<b>30-01</b>	140	black	Lynx, up tp G-type, and all		
	<b>30-601</b>	140	graphit	utility models		
	<b>30-010</b>	163	black	Skidoo old models up to -96		
<b>Trapper, Nordik</b>	Trapper, Nordik-300,500,600					

Skidoo Nordik	Width L mm		height H	thickn S	B ,mm	T ,mm
	<b>37</b>		<b>20</b>	<b>10</b>	<b>7</b>	<b>24,5</b>
	Number	length cm	color	Nordik 377 R, 540, 550		
	<b>30-00</b>	155	white.			

Skidoo, Lynx	Width L mm		height H	thickn S	B ,mm	T ,mm
	<b>38</b>		<b>17</b>	<b>9,5</b>	<b>4,5</b>	<b>22</b>
	Number	length cm	color			
	<b>30-21</b>	140	black	Lynx G-type-,		
	<b>30-621</b>	140	graphit	Skidoo REV, RT & RF, SC4 suspens.		
	<b>30-210</b>	163	black			
	<b>30-321</b>	140	yellow			

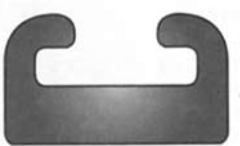
Skidoo, Lynx	Width L mm		height H	thickn S	B ,mm	T ,mm
	<b>38</b>		<b>15</b>	<b>7</b>	<b>5</b>	<b>27</b>
	Number	length cm	color	Formulat, GT mod., Mach1, Z, MXZ,		
	<b>30-260</b>	140	black	Legend, MX Rev, Summit, Renegade		
	<b>30-270</b>	151	graphit			
	<b>30-280</b>	163	black			
	<b>30-360</b>	140	yellow			
	Lynx 2009- RS 600, SC 4 suspension,					

# Runner shoe

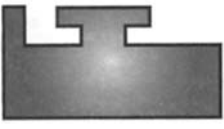
<b>Polaris</b>	Width L / L mm		height H	thickn S	B ,mm	T ,mm
	<b>31</b>	<b>37</b>		<b>11</b>		
	Number	length cm	color			
	<b>30-15</b>	140	black	Up to 2000 all		
	<b>30-615</b>	140	graphit	XTRA 10, XTRA 12 narrow profile		
	<b>30-150</b>	145	black			
<b>note: dimensions</b>	<b>30-618</b>	140	graphit	Polaris- Storm, XCR, wide profile		

<b>Polaris</b>	Width L mm		height H / H	thic. S / S	B / B	T / T
	<b>32</b>		<b>19,5</b>	<b>22,0</b>	<b>9 / 11</b>	<b>5 / 6</b>
	Number	length cm	color	Edgr RMK 03-05, Edge 2000-05,		
	<b>30-23</b>	140	black	340 mallit -99-05, Lite 97-98		
	<b>30-623</b>	140	graphit	Indy Sport -97-99,		
	<b>30-230</b>	167	black	2000-		
<b>note: dimensions</b>	<b>30-240</b>	163	black	gen II RMK, XC, M-10 , Indy Edge		

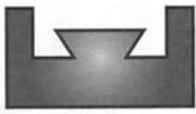
<b>Yamaha</b>	Width L mm		height H	thickn S	B ,mm	T ,mm
	<b>30</b>			<b>7</b>		
	Number	length cm	color	Phaser, Ovation, SRV, SS		
	<b>30-12</b>	140	black			
	<b>30-612</b>	140	graphit			

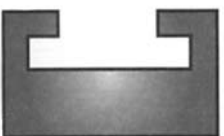
<b>Yamaha</b>	Width L mm		height H	thickn S	B ,mm	T ,mm
	<b>30</b>		<b>15</b>	<b>7</b>	<b>5</b>	<b>24</b>
	Number	length cm	color			
	<b>30-16</b>	140	black	Viking, Exciter 87-90, Phaser 90-99		
	<b>30-616</b>	140	yellow	V-max 92-97,		
				V-max 500-600 94-96		

<b>Yamaha</b>	Width L mm		height H	thickn S	B ,mm	T ,mm
	<b>30</b>		<b>18</b>	<b>10</b>	<b>5</b>	<b>24</b>
	Number	length cm	color			
	<b>30-20</b>	140	black.	V-max 97-03,		
	<b>30-200</b>	145	black	Mountain max 97-02		
	<b>30-620</b>	140	graphit	SX, SRX, SXR, 98-04		

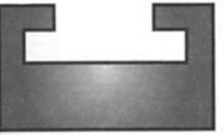
<b>Yamaha</b>	Width L mm		height H	thickn S	B ,mm	T ,mm
	<b>34</b>		<b>18</b>	<b>10</b>	<b>5</b>	<b>25</b>
	Number	length cm	color			
	<b>30-625</b>	145	graphit	RX1 models 2005- RS models 2005-		
	<b>30-635</b>	157	graphit	Apex, Attack 2006-		
				Nytro 2006-		

## Start spring

<b>01-1560</b>	Rotax	414 783 400
<b>01-158</b>	Rotax	420 939 115
<b>01-2080</b>	Arctic Cat Polaris Yamaha	3001-077 308-3185 8YO-15713-00-00
<b>01-2083</b>	Arctic Cat Polaris	3002-921 308-3495
<b>01-206</b>	Sachs	
<b>01-207</b>	Kohler	

## Pawl kit Rotax

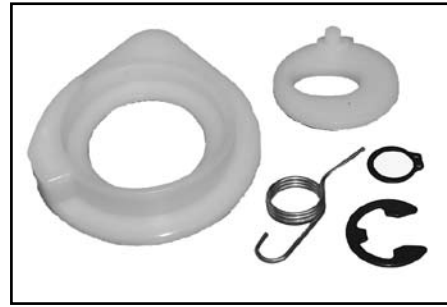

**01-154**



**01-153**

## Spring, front / pair



**41-3281** 8,0mm mm. Lynx 250,3900

**41-3000** 9,0mm mm. Lynx 5900



**41-8797** 10mm mm. Ranger King  
538797, 538798

**41-8796** 9,0mm 538796, 538795



**41-1530** 9,0mm mm Lynx 5900,  
ring and hook

**40-4715** 8,5mm Nordik 500, 540, 550, 600



**40-CA** 8,0mm mm. Karibo, Arctic Cat

## Rear springs / heavy duty / pair



**40-PZ** Yamaha Phazer 07-



**40-LT** Yamaha Mt. Lite

## Rear springs / heavy duty / pair



**40-AC 11,5 MM**  
Arctic Cat the last models



**40-POLA 11,5 MM**  
8 turns  
Polaris, Skidoo, Lynx



**40-VI 12,0 MM**  
Yamaha Viking



**40-PO 11,5 MM**  
9 turns  
Polaris onward 1990



**40-EDGE 11,0 MM**  
Polaris EDGE



**40-POL 11,5 MM**  
Polaris up to 1989, with hook

## Rear springs / normal / pair



**41-8805 Lynx Ranger**



**41-4175 Lynx 3900 S**



**40-4721 Nordik 500-600**



**41-1531 Lynx**



**41-4277 Lynx 10,0 MM**  
Right hand springs shown in the pictures.



**41-4500 Lynx 9,0 MM**      **40-4716**

# Drive shaft 5900

## 11-59 drive shaft 5900

For 1989-1995 makes



### Rear shaft



<b>11-02</b>	3450701	Lynx 250, 360
<b>11-03</b>	3501775	Lynx GLX, 5900, 650
<b>11-04</b>	3501911	Lynx GLX, 5900, 650
<b>11-08</b>	5492814	rear shaft Lynx 250
<b>11-09</b>	5493615	rear shaft Lynx 5900
<b>11-10</b>	5496216	rear shaft Lynx 360, 3900
<b>11-11</b>	05032390	rear shaft Nordik 500, 540
<b>11-12</b>	05032389	rear shaft Nordik 300, 377R

### Counter shaft



<b>11-20</b>	5394111	Lynx 250S, 3900S
<b>11-21</b>	5398073	Lynx 360S, Ranger
<b>11-22</b>	539990	Fox -99
<b>11-23</b>	5146138	Fox 00-
<b>11-25</b>	875138073	Syncro

### Hood latch



**12-13402**



**12-135**

12-13402  
Lynx, Yamaha



**12-131**

12-135  
Polaris 75-83



**12-13501**

12-131

12-13501  
Polaris 84-05



## New, new

### 43-27

Sprocket **8751-46293**  
 27 teeth v. 1989-1997  
 Lynx 5900, 3900, 6900



### 43-68 600cc liquid cooled years.2002-05

Sprocket **Z=53 8751-56114**  
 Sprocket **Z=31 8751-56156**  
 Sprocket **Z=28 8751-56206**



### 43-32

Sprocket **8751-46042**  
 32 teeth  
 v. 1989-1996  
 Lynx 5900, 3900, 6900



## Syncro gears

### 43-65 from 1992

sprocket, wide z=64 8751-55048  
 sprocket, left z=33 8751-47643  
 sprocket, right z=33 8751-47644

### 43-64 up to 1992

sprocket, wide z=64 8751-55048  
 sprocket, left z=31 8751-47202  
 sprocket, right z=31 8751-47203



## Sisu gear box

### 43-66

**1996-2003**

sprocket Z=55 8751-56048  
 sprocket Z=31 8751-56049  
 sprocket Z=28 8751-56050

# Bearings

Number	hole x od x width.	to use for
35-6201	12 x 32 x 10	
35-6202	15 x 35 x 11	
35-620258	15,875 x 35 x 11	
35-6203	17 x 40 x 12	
35-6204N	20 x 47 x 14	
35-6303	17 x 47 x 14	
35-6304	20 x 52 x 15	
35-6205N	25 x 52 x 15	
35-CB205	25 x 52 x 15	cone
35-SC205T	25,4 x 52 x 15	cone
35-6004	20 x 42 x 12	
35-6005	25 x 47 x 12	
35-6006	30 x 55 x 12	
35-6008	40 x 68 x 15	
35-6022	22 x 44 x 12	
35-6228	28 x 58 x 16	
35-SA205T	25,4 x 52 x 15	spherical with collar
35-UC205	25 x 52 x 17	with screw
35-UC205T	25,4 x 52 x 17	
35-SB205	25 x 52 x 15	
35-SB205T	25,4 x 52 x 15	
35-AS205	25 x 52 x 15	spherical, plain, yamaha drive shaft
35-RB205	25 x 52 x 15	like UC 205, but plain, yamaha drive
35-3205	25 x 52 x 21	2-row, Lynx gearbox
<b>rev bearings</b>		
35-CB205	25 x 52 x 15	drive shaft
35-62/28	28 x 58 x 16	chaincase upper
35-62/28	28 x 58 x 16	chaincase, lower
35-SA205T	25,4 x 52 x 15	counter shaft
<b>xp bearings</b>		
35-6205	25 x 52 x 15	counter shaft
35-6010	50 x 80 x 16	drive shaft
35-6010	50 x 80 x 16	drive shaft, chaincase

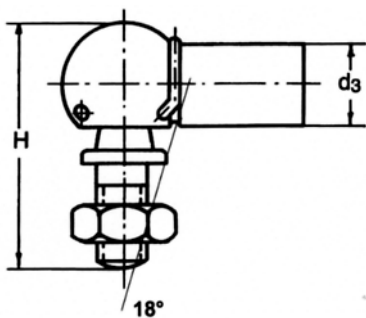

## Rod end

35-OAS16  
35-VAS16

Rod end M10 right  
Rod end M10 left

# Gaskets



08-101

**Rotax 377-447-503**  
manifold

08-100

**Rotax 377-447-503**  
carburetor

08-102

**Polaris**  
manifold

## Repair kits ( MIKUNI )



08-103

**Mikuni ( 07-187-05 )**

08-104

**Mikuni ( 07-187-11 )**



03-7000

**Primer pump**



03-7311

**In tank filter**



# Throttle extension kit

03-5000 Throttle extension kit

20 cm



# Fuel pumps



31 l.

08-188



70 l.

08-200



08-187

# Hook



12-01



12-02 Skidoo



12-03 Polaris



12-04  
12-04XP

**Skidoo**  
**Skidoo -09-**  
**Lynx 09-**

# Extra wide skis

<b>31-01</b>	Width	250 mm	<b>8 mm</b>	design model
<b>31-02</b>	Width	200 mm	<b>8 mm</b>	
<b>31-03</b>	Width	230 mm	<b>8 mm</b>	
<b>31-09</b>	Width	230 mm	<b>8 mm</b>	<b>Polaris 08-</b>
<b>31-00</b>	Alpine II		<b>8 mm</b>	
<b>31-04</b>	Width	195 mm	<b>8 mm</b>	



**31-04 Vuotsolainen for Pilot / RMK ski, design model width 195 mm, 8 mm**



**You can use 1, 2, or 3 carbide runners**



**31-04**

**31-04** Vuotsolainen for Pilot ski

**31-03 L / left**

230 mm

Vuotsolainen for Pilot ski

**31-03 R / right**

230 mm

Vuotsolainen for Pilot ski



**31-05 Yamaha Viking, with pre-holes**



**33-50**

**33-50** Narrow Pilotti ski



# Plastics for plastic skis



**33-10 Arctic Cat**



**33-30 Katamaran ski**



**33-40 Polaris**



**33-60- Skidoo / Lynx flex**



**33-20 Lynx CTRL  
not pre-drilled, multipurpose**



**33-50 Pilot, narrow model**



**33-70 Skidoo1996-**



**33-80 Yamaha SRX 1998-**



**33-90 Yamaha 2000 / Skidoo / Lynx**



**33-99 Yamaha RX-1**

**31-06 Bottom pan  
6 x 800 x 1000 mm**

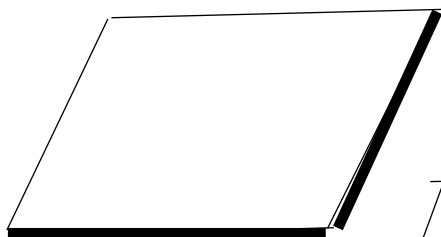

**31-00-20 Alpine II**



**Plastic  
31-07  
31-08**

**8 x 150 x 3000  
8 x 150 x 2000**

# Plastic ski skins

# 8 mm HPDE.

 <b>32-01 Arctic Cat</b>	 <b>32-06 Arctic Cat</b>
 <b>32-00 Ockelbo</b>	 <b>32-11 Trapper, Nordik</b>
 <b>32-99 Safari, Scandic 380</b>	 <b>32-21B Formula, Snowexpert</b>







This ski needs normal runner **MM277** and Carbide **MM147**  
**Ski skin 33-90** fits nice this blow moulded Skidoo ski

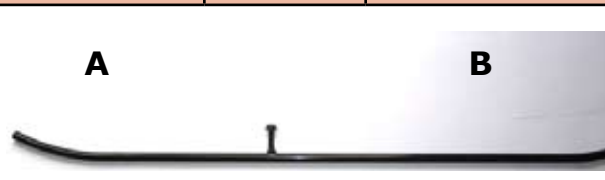
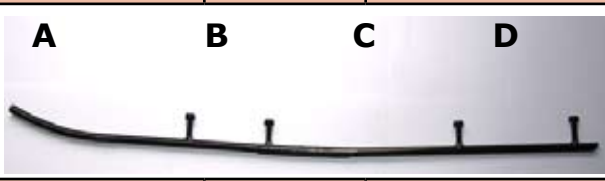
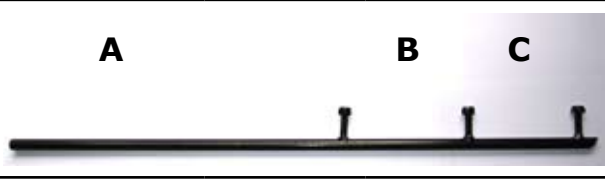
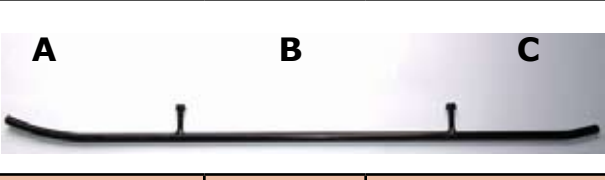
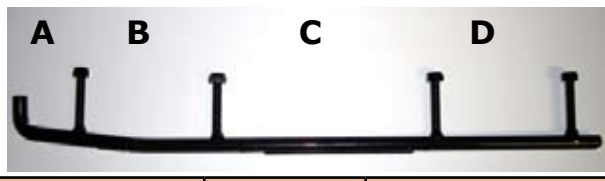
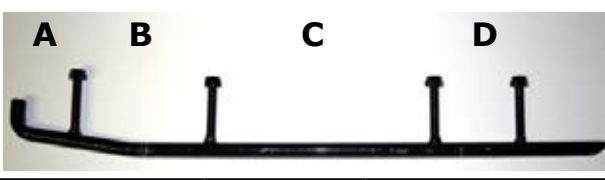
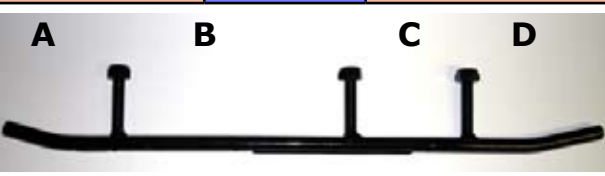

 <b>32-61 Lynx</b>	 <b>32-41 Polaris 1993-</b>
 <b>32-51 Polaris -92, Ockelbo</b>	 <b>32-81 Yamaha Viking</b>
 <b>32-88 Yamaha Phaser 98-</b>	 <b>32-91 Yamaha V-max 94-</b>

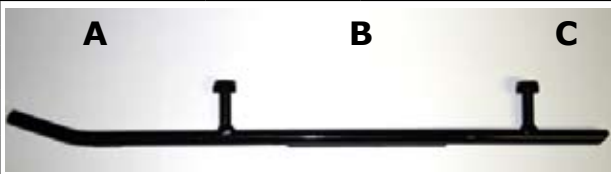
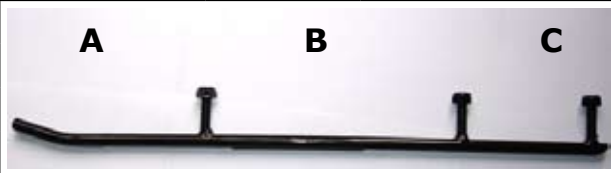
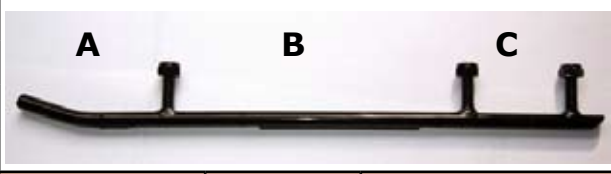
# ARCTIC CAT

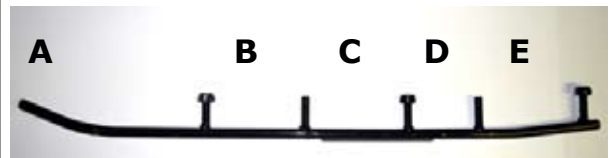
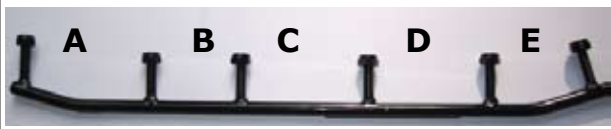
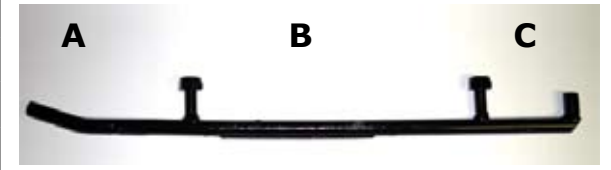
# Ski runners

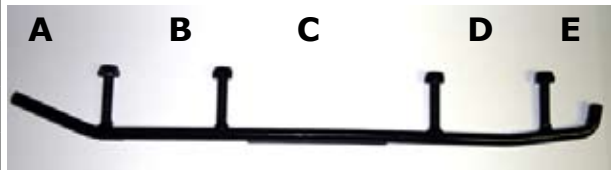

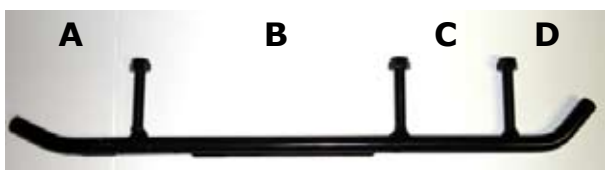
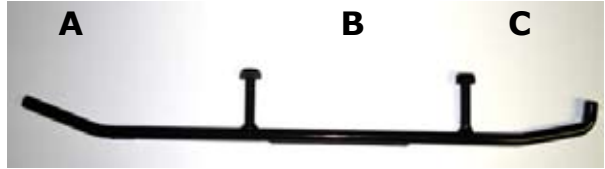

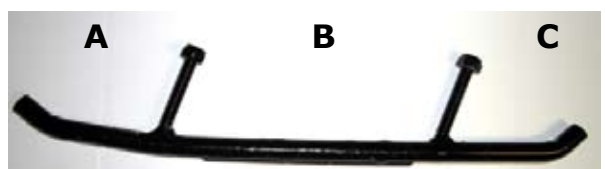
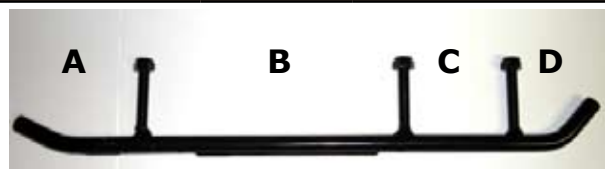
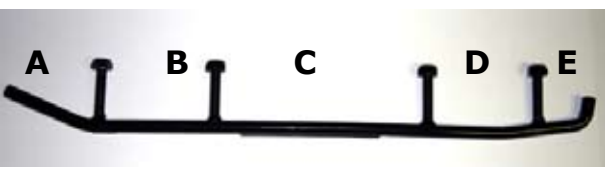
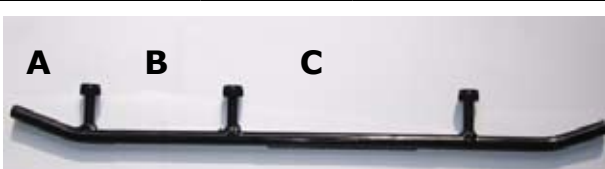
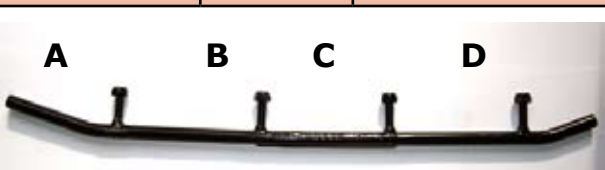
Normal	Racing	Carbide	L=length	A	B	C	D	E	
MM203		MM169	772	386	386	-	-	-	
			<b>AKTIV:</b> Alaska, Panther, Karibo 1984-1986, and also <b>ARCTIC CAT:</b> El Tigre 1980-84, Jag 1980-91, Panther 1980-89, Super Jag 1987-92 Trail Cat 1980-81, Pantera 1980-85						
MM205		MM170	776	343	433	-			
			Cheetah Tour 1987-91, Cougar 1987-91 El Tigre 1987-90, Jag AFS 1989-91 Manx 1991-, Pantera 1987-90 Panther 1990-91, Wild Cat 650 1988-90						
MM260		MM133	787	260	108	249	162		
			Ext Special 1992, Ext 580,Z 1993-94, Jag Special, Z 1992, Prowler Spec. 1992-94 Wild Cat 700 EFI 1992-94, ZR 440 1993-95 ZR 580,700 1993-95, Thunder Cat 1996						
MM210		MM173	610	356	127	114			
			Bear Cat 340,440 1995-99, Cheetah Tour 1992-94 Cougar 1992-97, Ext, EFI 1992-93, Manx 1992-93 Jag AFS DL 1992-93, Prowler 2-UP 1992-94 Pantera 1992-97, Panther 1992-93, Prowler 1991-96 Thunder Cat 1993-95 Puma 1991-97, Wild Cat EFI 1992						
MM261			791	236	380	193			
			El Tigre 1985-86 Cougar 1985-86 Cheetah 1986 Pantera 1986						
MM262		MM157	469	57	114	178	114		
			Plastic skis 1996-						
MM263		MM158	469	57	114	178	70		
			Plastic skis 2005-???						
<h2>SLP ski</h2>			<h2>SLP ski</h2>						
MM290	MM390	MM190	470	89	179	90	112		
			SLP ski On the photos, the front of the runner is on the left side, always.						

Normal	Racing	Carbide	L=Length	A	B	C	D	E	
<b>MM242</b>		<b>MM189</b>	<b>470</b>	<b>170</b>	<b>235</b>	<b>65</b>			
			Forest Fox 1999-, GL360, 250 1991-93, GL 2300 -90 GL 3300 1989-90, GL 3900, LTS 1991-92 GLS 3900 1989-90, GLX 5900, LTS 1991-93 GL Sport, LTS 1991-92, Ranger 1993						
<b>MM230</b>		<b>MM187</b>	<b>550</b>		<b>235</b>				
			GL 250. 250S 1986-89, GL 3900 1983-88 GL 5900 1983-90 535, 650 1983-87 640 1988						
<b>MM240</b>		<b>MM188</b>	<b>450</b>		<b>228</b>	<b>81</b>			
			GLS 3300 1986-89, GLS 3500 F/C 1990-93 GLS 3600 L/C 1990-91, Cobra 1992-93 3800 Rave, Ultra, Cobra Touring, Rave , Cobra Racing, Enduro 1993						
<b>MM241</b>			<b>450</b>		<b>219</b>				
			230, 250, 650 1989-93						
<b>MM265</b>		<b>MM154</b>	<b>660</b>	<b>215</b>	<b>110</b>	<b>114</b>	<b>80</b>	<b>122</b>	
			G-type Rave 1997-99 Enduro 600						
		<b>MM153</b>	<b>530</b>	<b>120</b>		<b>115</b>	<b>110</b>	<b>80</b>	
			G-type Racing 1998- Sport XR 98						
		<b>MM152</b>	<b>440</b>	<b>130</b>	<b>228</b>	<b>77</b>			
			G-type 1997-99 Enduro 500						
<b>MM250</b>		<b>MM193</b>	<b>625</b>	<b>321</b>	<b>241</b>	<b>63</b>			
			Ranger short steel ski of Skidoo 2000-						
<b>MM279</b>		<b>MM146</b>	<b>537</b>	<b>90</b>	<b>103</b>	<b>190</b>	<b>103</b>	<b>54</b>	
			<b>FLEX</b> plastic ski 2000- Fit also Skidoo						

Normal	Racing	Carbide	L=Length	A	B	C	D	E	
MM277		MM147	400	87	177	75	60		
			Plastic, <b>Camoplast</b> ski 2003- Also for Skidoo and Polaris						
MM243	MM386	MM186	520	210	192	121			
			<b>ADJ</b> ski, <b>CTRL</b> ski 2003- The rear is bent for easier assembly of ski and plastic skis						
MM255			520		192				
			ADJ ski with three bolts						
<b>SKI-DOO</b>									
MM274		MM144	335	89	160				
			<b>Pilotti</b> ski/ Skidoo, narrow and wide						
MM277		MM147	400	87	177	75	60		
			Plastic, <b>Camoplast</b> ski 2003- Also for Skidoo and Polaris Skandic 380-550 2003-						
MM279		MM146	534	84	103	190	103	54	
			Plastic ski <b>FLEX</b> 1997- Also Lynx						
		MM141	445	54	95	222			
			Formula 583 1998 Formula III 600, 700 1997-99 Formula Mach I, Z 1997-99, Formula Z 1997-99 G-Touring 583, 670 1997-99, Summit 1997-99						
		MM142	502	90	126	110	116	60	
			MXZ 440, 583, 670 1996-99						

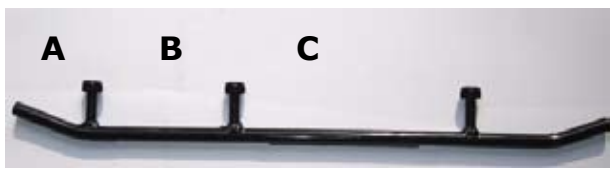
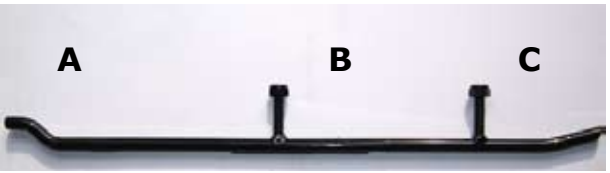
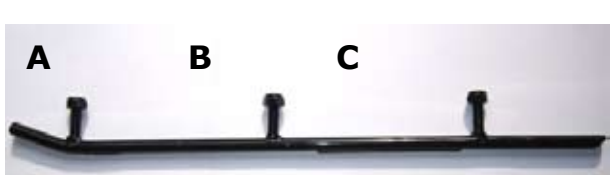
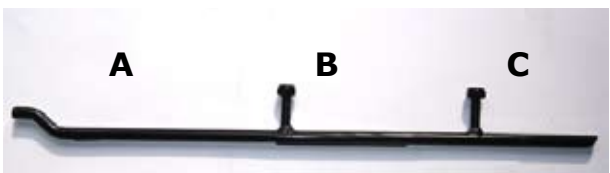
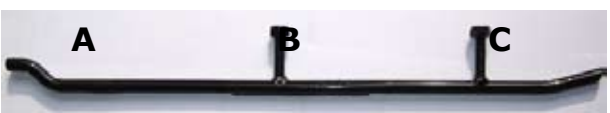
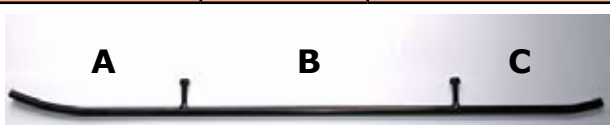







# SKI-DOO



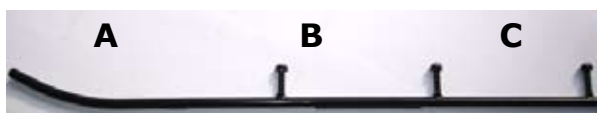
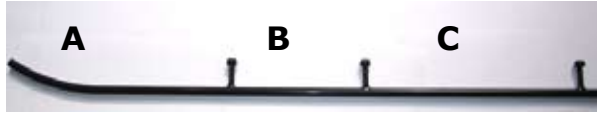

# Ski runners

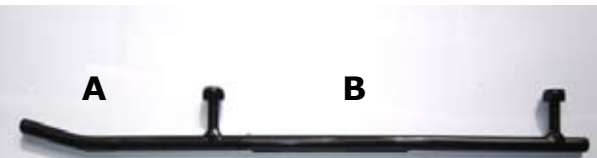
Normal	Racing	Carbide	L=Length	A	B	C	D	E	
		<b>MM143</b>	<b>495</b>	<b>54</b>	<b>120</b>	<b>196</b>	<b>115</b>		
			Formula III 1985-96, Formula Mach Z 1985-96						
			Formula MXZ 1993-95, Formula Z 1994-96						
			G-Touring 583, 670 1993-96						
			Summit 1994-96						
<b>MM229</b>			<b>602</b>	<b>248</b>	<b>176</b>				
			Formula SP DL 1985-86, Tundra 1985-97						
			Safari 377, 447, 503 1984-88						
			Safari, Saga, Scout 1989-92						
			Skandic 377, 503 1986-87						
<b>MM216</b>		<b>MM163</b>	<b>602</b>		<b>170</b>	<b>170</b>	<b>99</b>		
			Formula Mach I 1989-94, Formula SS 1995-96						
			Formula MX, XTC 1985-95						
			Formula Plus, XTC 1985-93						
			Formula ST, STX 1994-96, Grand Touring 470 -95						
Safari DL, 503 Rally 1993-94, Safari GLX, LCE, L 1990-94, Skandic II 377, 503 92-94									
<b>MM275</b>		<b>MM145</b>	<b>545</b>		<b>178</b>	<b>114</b>			
			Blizzard 1978-84, Nordik 1981-83						
			Everest 1974-83, Olympique 1976-79						
			Skandic 277, 377 1982-85						
			TNT 1973-78						
<b>MM215</b>		<b>MM176</b>	<b>527</b>	<b>238</b>	<b>177</b>	<b>112</b>			
			Safari Cheyenne 1989-91						
			Alpine II 1991-95						
<b>MM211</b>		<b>MM174</b>	<b>483</b>	<b>162</b>	<b>178</b>				
			Citation 1980-91						
			Elan 1971						
<b>MM250</b>		<b>MM193</b>	<b>625</b>	<b>321</b>	<b>241</b>	<b>63</b>			
			Formula 500, DL 1996-99						
			Formula 583 1996-99, Formula S, SL, SLS 95-99						
			G-Touring 500 1996, Scandic 380, 500 1995-						
<b>TRAPPER, NORDIK</b>									
<b>MM215</b>		<b>MM176</b>	<b>527</b>	<b>238</b>	<b>177</b>	<b>112</b>			
			Nordik 300-377						
			Nordik 500-600						
			Nordik 540-600 SL						
<b>MM227</b>		<b>MM171</b>	<b>480</b>	<b>250</b>	<b>148</b>	<b>82</b>			
			Nordik 500 PSS,						
			Nordik 550						

# POLARIS

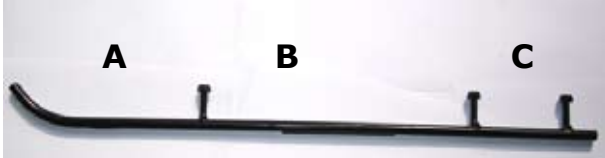
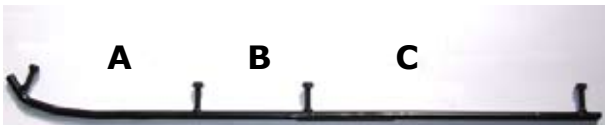
# Ski runners

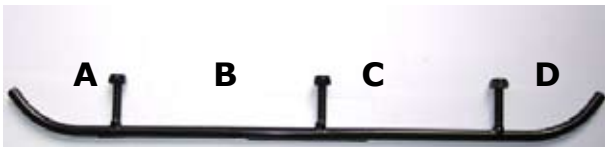
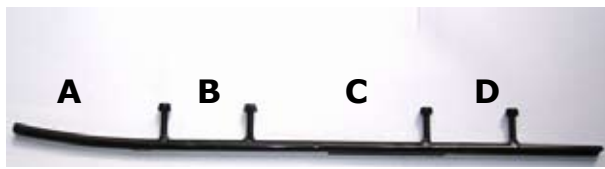
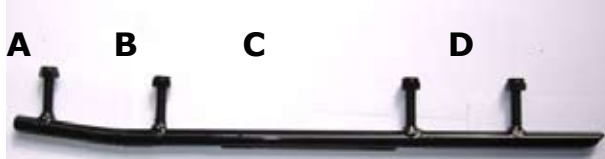
Normal	Racing	Carbide	L=Length	A	B	C	D	E	
MM202	MM348	MM148	722	180	160	178	178		
			<b>Plastic skis 2007-</b> <b>Replaces original</b> <b>MM348 racing runner</b>						
MM270		MM149	680	310	178	178			
			Plastic skis 1997- Indy RMK 700, Indy XC 400, Indy XCR 600 1997- Indy Storm, Indy Ultra 1997-						
MM206		MM159	673	317	178	178			
			All mod. 1988-98 All with steel skis 1998-99 Indy Sport 1987						
MM209		MM177	813	317	178	255			
			Indy 400, 600, Trail, Longtrack, Sprint SS, Star, Startrack 1986-87						
MM208			813	405	408				
			All makes 1971-82 Indy 600, 400, Trail, Longtrack, Sport, SS, Star, LT 1983-85						
	MM398								
			<b>Polaris Gripper ski</b>						
<h2>Ockelbo</h2>									
MM207		MM160	800	395	405				
			All mod. -1986 <b>Ockelbo</b>						
MM228		MM162	450		270				
			All mod. 1987- <b>Ockelbo</b>						
<h2>YAMAHA</h2>									
MM219			578	57	184	311			
			BR 250 1982-94 ET 250, 300, 340 1977-84 SR 540 1980-84 SRX 440 1976-80						

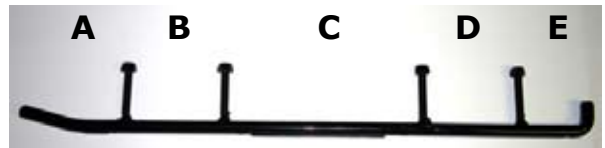
Normal	Racing	Carbide	L=Length	A	B	C	D	E	
MM217		MM138	621	60	174	268			
			ET 340 1985-88						
MM224		MM164	635	216	292	101			
			Exiter 570 1987-90						
			SR 540, V-MAX 540 1987-91						
MM280		MM137	768		140	360			
			BR 250 T, TS 1984-98						
			ET 340 T, TR 1981-88						
			ET 400 T, TR 1989-91						
			EX 340, 440 1977-81						
MM232		MM166	663	57	183	210	101		
			CS 340 1990-99, Exiter II 570, SX 1991-93						
			Phazer II, E, ST 1984-99, SR 540 1985-86						
			V-Max 540 1983-86, Viking II 540 1988-92						
			XLV 540 1985-91						
MM235		MM175	604		181	210			
			ET 410 TR 1992-99						
			Viking II 540 E 1993-99						
			Venture 480 1991-99						
MM251		MM194	608	159	90	185	90		
			V-Max-4 1992-94						
			Venture 500,600,700 1995-96						
			V-Max 500, 600, 700 1994-96						
			V-Max 800 1995-97						
MM281		MM136	419		82	176	59	62	
			V-max 500, 600, 700 1997-99						
			Venture 500,600,700 1997-99						
MM282		MM135	475		124	160	118		
			SRX 600, 700 1998-						
MM239	MM339	MM139	530	100	90	180	90	70	
			RX, RX-1 2002-						

# Powerbloc 80

Maintenance-free clutch now for powerfull liquid cooled engines This clutch does not have sleeves, levers or other parts that could be damaged. Very reliable. On the clutch can be installed the original starter ring. Clutch is supplied pre-calibrated



Clutch has been on sale in the beginning of 2008.



## Polaris

You can find all calibrations on our web page at:  
[www.teolehtimaki.fi/spare parts catalogue](http://www.teolehtimaki.fi/spare_parts_catalogue)

15-84	All engines 488 cc	1989-
15-84	600 cc 2-cyl	1997-07
15-84	600 cc 3-cyl	1996
15-84	700 cc 2-cyl	1997-06
15-84	800 cc 2-cyl	2000-05
15-84	750 cc 4-tahti turbo, 4-stroke turbo	2006-



### Polaris cones:

Left, Fuji engine, ab. 28 mm long  
 Right, USA engine, ab. 33 mm long

The clutch 15-84 fits all Polaris makes, also Fuji. The angle of cone is the same, it is longer.

**Note: Fuji engineclutches does not fit to the engines of USA**

## Arctic Cat

Small cone		
15-85	All less than 700 cc engines	
Big cone on the following engines from 2003		
15-86	<b>599 3D 2-cyl. 114 hp 31 mm</b>	2003-
15-86	<b>658 cdi 3-cyl. 110 hp 4-stroke, 31 mm</b>	2003-
15-86	<b>698 3D 2-cyl. 140 hp 31 mm</b>	2003-

# Skidoo & Lynx

<b>15-81</b>	Rotax 453	MXZ 440 LC X
<b>15-81</b>	Rotax 593, 500SS	1999-2008
<b>15-81</b>	Rotax 693 2-cyl	1999-
<b>15-81</b>	Rotax 699 3-cyl	1996-
<b>15-81</b>	Rotax V-810	2007-
<b>15-81</b>	Rotax V-1000	2003-
<b>15-81</b>	Rotax V-1200	2009-
<b>15-82</b>	Rotax 493, 494	1996-
<b>15-82</b>	Rotax 593HO,600 SDI	2003-2004
<b>15-82</b>	Rotax 670	1993-
<b>15-84</b>	Rotax 582, 583, 643	1993-

Makes 15-81 and 15-82, big cone. Without gear ring both makes can be used. But 15-84, small cone.

## Yamaha

15-83	500, 494 cc	1994-2001
15-83	600 cc 2-cyl	1994-1999
15-83	600 cc 3-cyl	1999-2002
15-83	700 cc	1996-2002
4-tahti, 4-stroke		
15-83	499 cc 80 hp	2007-
15-83	973 cc 120 hp	
15-83	998 cc Rx 1	2003
15-83	1049 cc	2008-



## P80 springs

Number		N min/ 72 mm	N max / 45 mm	Length	A dia.
<b>15-91</b>	<b>0451-1135</b>	900	1300	138,0	5,50
<b>15-92</b>	<b>0451-1136</b>	900	1600	109,0	6,00
<b>15-93</b>	<b>0451-1132</b>	810	1150	143,0	5,50
<b>15-94</b>	<b>0451-1134</b>	742	1612	95,0	6,00
<b>15-95</b>	<b>0451-1109</b>	300	1100	82,0	6,00
<b>15-96</b>	<b>0451-1114</b>	400	900	95,0	5,50
<b>15-97</b>	<b>0451-1133</b>	800	1300	121,0	5,50
<b>15-98</b>	<b>0451-1113</b>	400	700	111,0	4,90
<b>15-99</b>	<b>0451-1128</b>	700	900	176,0	4,75



**Puller for  
P50, P80, TRA  
Part number: 18-212**

## P50 clutch

The part number is blue

All calibrations are on the pages:

[www.teolehtimaki.fi/spare parts catalogue](http://www.teolehtimaki.fi/spare_parts_catalogue)

Our home page is updated frequently to assure most up-to-date information on our products.

Number	S4B	P50 number	CVTech	PTO	Belt	x	Use
15-01	6513B	0403-0001		3,65	31,2		<b>15-02</b>
15-02	5913B	0403-0002		2,50	31,7		<b>15-02</b>
15-03		0403-0003	15-0147C	8,77	34,8	8	<b>15-03</b>
15-04		0403-0004	15-0148C	8,77	34,8	8	<b>15-04</b>
15-05	0513B	0403-0005		11,5	33,3	6	<b>15-05</b>
15-06	8113B	0403-0006	15-0149C	6	34,9		<b>15-06</b>
15-07	5413B	0403-0007		7,5	34,9		<b>15-06</b>
15-09	9513B	0403-0009		11,5	34,9	6	<b>15-09</b>
15-10	9713B	0403-0010		5	33,3		<b>15-10</b>
15-11	9213B	0403-0011	15-0151C	1,5	34,9		<b>15-11</b>
15-18	9113B	0403-0018	flange	4,99	34,9		<b>15-18</b>
15-19	9613B	0403-0019		8,58	34,9	6	<b>15-19</b>
15-20		0403-0020		8,77	34,8	8	<b>15-03</b>
15-21	9313B	0403-0021	flange	0,06	34,9		<b>15-21</b>
15-22	3113B	0403-0022	flange	0,06	32,7		<b>15-22</b>

X = srew for ring gear, 6 mm or 8 mm

## P50 springs

Number	CVTech	N min /	N max /	Length	A dia.	Note
		72 mm	45 mm	mm	mm	
<b>15-52</b>	0151-0002	618 / <b>637</b>	1050 / <b>1115</b>	110 / <b>108</b>	5,26 / <b>5,50</b>	+ 1
<b>15-51</b>	0151-0003	730 / <b>730</b>	987 / <b>1056</b>	158 / <b>132</b>	4,88 / <b>5,50</b>	+ 1
<b>15-55</b>	0151-0004	728 / <b>708</b>	1110 / <b>1056</b>	134 / <b>127</b>	5,26 / <b>5,50</b>	
<b>15-53</b>	0151-0006	500 / <b>499</b>	1070 / <b>1142</b>	095 / <b>93</b>	5,71 / <b>6,00</b>	
<b>15-54</b>	0451-1118	500 / <b>501</b>	700 / <b>832</b>	148 / <b>114</b>	4,50 / <b>5,50</b>	+ 1
<b>15-55</b>	0451-1129	700 / <b>708</b>	1100 / <b>1056</b>	123 / <b>127</b>	5,26 / <b>5,50</b>	
<b>15-56</b>	0451-1137	595 / <b>604</b>	852 / <b>929</b>	135 / <b>122</b>	4,88 / <b>5,50</b>	+ 1

When the engine is running at full RPM, the spring rating is somewhat higher on the **Blue Spring** than the spring rating of the CVTech spring. The calibration can be adjusted by adding one shim into each block. Remember that one shim corresponds to 100 RPMs.

If the engagement RPM differs from the rated RPM of the motor, always check the spring adjustment and the alignment of the powerline.

## ALT-clutch



**15-1213A**



**15-0513A**



**15-2913A**



**15-3113A**



**15-1713A**

Arctic Cat		p/n	spring	shims	weight
All models	1970-80	1213	ask	ask	
Jag 4000	1981	1213	3	10	
Pantera 5000	1977-81	1213	3	12	
Panther 4000	1977-81	1213	3	9	
El Tigre 5000	1978-80	1213	3	12	
Trail Cat 4000	1980-81	1213	3	10	
<b>Ski-Doo</b>					
Alpine640	1969-75	0913	3		150
Alpine640	1975-82	0613	3		150
Citation 4500/SS	1980-83	0513	1	9	
Citation LS/E	1985-91	3913	1	12	
Elan 250/247cc	1971-96	1013	1	12	
Elan 248-294 cc	1973-79	1013	1	4	
Elite 464 cc	1975-79	0513	1	12	
Everest TNT	1975-79	0513	1	4	
Everest 444/464	1978-83	0513	1	12	
Everest 500	1980-83	0513	1	9	
Olympic mod	1969-75	1013	ask	ask	ask
Skandic 277	1983	3913	2	6	
Scandic 377 / R	1982-87	0513	1	9	
Tundra LT / LTS	1985-92	3913	1	12	
Skidoo models	1965-80	kysy	ask	kysy	ask
<b>Polaris</b>					
Polaris models	1970-80	2815	ask	ask	ask
Star, L/T	1983-87	2815	1	4	
<b>Yamaha</b>					
BR 250	1982-84	2913	1	13	
BR 250 TS, T, LT	1984-01	3113	1	12	
ET 250	1977-81	1713	1	4	
ET 300	1979-84	2913	1	4	
ET 340E, T, TR	1978-88	2913	1	6	
ET 400T, TR	1989-91	2913	1	11	
EC 340 338 cc	1981-88	2913	1	6	
EC 540 535 cc	1979-82	2913	1	12	
EX 340 338 cc	1976-78	2913	1	6	
EX 440 433 cc	1976-81	2913	1	13	
Phazer 433 cc	1984-89	3113	1	13	
SRV 540	1984-91	3113	1	12	
SRX 440	1976-80	3113	1	13	
SS 440	1980-85	3113	4	13	
STX 340	1976-77	2913	1	6	
STX 440	1976-77	2913	1	13	
XLV 540	1985-90	3113	1	12	
<b>Motoski</b>					
Motoski	1973-80	ask	ask	ask	ask
Futura 400, E	1977-79	0513	3	8	
Futura 444, LC	1978-79	0513	3	7	
Futura 464, RV	1980-83	0513	3	10	
Futura 500	1980-83	0513	3	10	
Mirage 1.	1980-83	0513	2	10	

## ALT-clutch



15-3913A



16-11



16-06



16-09



16-08



16-07



16-02

Lynx		p/n	spring	shims	weight
L 320 295 cc	197?-80	1213A	1	9	
L 520 295 cc	197?-83	1213A	1		60
L 330 340 cc	197?-80	1213A	1	8	
L 535 440 cc	197?-79	1213A	1		60
L 635 440 cc	197?-79	1213A	1		90
GLX 503 cc	1981-82	1213A	1		60
GLX / 5900	1984-93	0513A	1		60
L 535 503 cc	1981-83	1213A	1		60
L 535 503 cc	1984-87	0513A	1		60
L 635 / XL	1981-83	1213A	1		90
GL 3300 377 cc	1982	0513A	2	12	
GL 3900 377 cc	1982-91	0513A	2	12	
L 650 503 cc	1982-92	0513A	1		90
L 250, S 253 cc	1985-91	0513A	2	6	
GL 3300 S 503 c	1984-89	0513A	1	7	
GL 3300 377 cc	1989-90	0513A	1	12	
<b>Ockelbo</b>					
Oc 300	1978-80	3113A	2	14	
Oc 600-1	1978-80	3113A	2	14	
Oc 600-2	1979-81	0513A	2		60
Oc 8000	1980-88	0513A	2		90
Oc 6000	1980-88	0513A	2		60
Oc Poro	1983-85	0513A	2	6	
Oc 4000	1982-83	0513A	2	7	
Oc 5000	1983-88	0513A	2		60
Oc 3500	1986-88	0513A	2	6	
Oc 4500	1986-88	0513A	2		60
Fighter	1988	0513A	2	10	
<b>Trapper</b>		<b>Nordik</b>			
Trapper 5000	1984-	0513A	1	10	
Trapper 6000	1984-	0513A	1		90
Nordik 300, R	1988-	3913A	1	10	
<b>Aktiv</b>					
Aktiv models	1976-82	1213A	ask	ask	ask
Aktiv models	1983-	0513A	ask	ask	ask
<b>Terri 30</b>					
Terri	1975-	0513A	5		

## ALT Springs

Number	CVTech	length mm	min. kg	max. kg
19-12	X-5243212	70	11	171
19-02	X-5243300	76	43	182
19-01	X-5243302	79	53	192
19-03	X-5243304	83	69	209
19-04	X-5243306	86	85	211
19-05	X-5243308	89	94	213
19-06	X-5243310	92	104	216
<b>16-20</b>	X-5218300	76	30	127



**S4B-Clutch,  
Tundra II ,  
15-9713B**



**18-130**



**18-030**

**S4B spare parts**



**18-100**



**17-050**



**17-051**



**18-060  
18-090**



**18-140  
18-200**



**18-120**



**17-090**



**16-07**



**16-08**



**17-040 Cap**

**Driven pulley, spare parts**



**14-16  
cam**



**14-10  
shim**



**length 39 mm  
dia 38 mm  
outer d. 44,5 mm**

**14-08  
bearing**



**14-15  
cam 14- makes**

**P50 spareparts**



**19-100**



**19-120**



**19-170 screw  
19-171 polaris  
19-140 shim  
17-112 nut  
18-160 washer**



**19-050**



**19-130**



**19-030**



**16-08**



**16-07**

# Driven pulley

Vuosi Year	Malli, make, modelle	Ro- tax	osa # part #
	Terri 30, 2020		14-6038
	Trapper, Ockelbo		14-6024
1984-93	535, 5900 GLX, 650	503	14-6028
-93	GL 250	253	14-6028
-93	360, Ranger, GL3300	377	14-6028
1994-96	360 S, Ranger	377	14-6041
-96	Ranger 380, Fox, Light	380	tulossa
1994-96	GLX 5900FC, 650 S	503	14-6041
1994-96	GLX 5900 LC	493	14-6041
1997-98	Ranger 380,	380	tulossa
1997-98	Fox, S, Light Touring	380	tulossa
1997-98	GLX 5900 FC, 6900	503	14-6032
1997-98	GLX 5900 LC	493	14-6032
1999-03	GLX 5900 FC	503	14-6032
1999-04	6900	503	14-6032
1999-??	Fox 440	447	tulossa
1999-00	GLX 5900	493	14-6032
2000-	Ranger 500 FC	503	14-6032
2000-	Ranger 500 LC	493	14-6032
2001-	5900 ST	593	14-6032
2004-	SUV 550, Ranger	550	14-6032
2004-	6900	550	14-6032
2004-	SUV 600, ST 600	593	14-6033
2004-	5900 Yeti V-1000		14-0021
2005-	5900 Yeti 600 HO SDI	593	14-6021
2006-	SUV 600, Ranger 600	593	14-6021
2007-	TUV 600 HO SDI	593	14-6021
2007-	Yeti, Yeti Pro V-800	800	14-6021

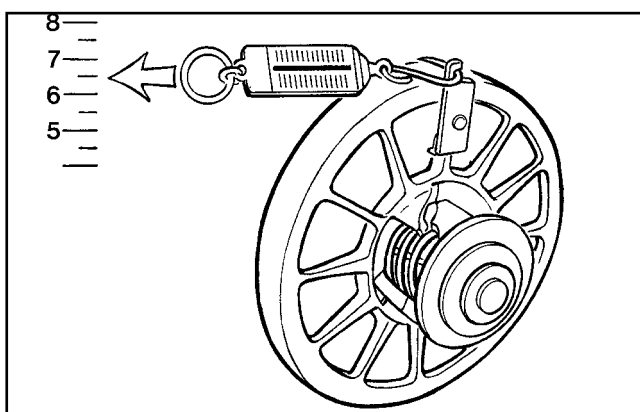

## Adjusting

Whenever you install a new clutch or repair the old one, always remember to check the tension and condition of the drive pulley spring.

Very often the spring is weak and unable to perform properly. If the spring in the drive pulley is weak, it allows the clutch to shift too early and causes the engine to run inefficiently. When replacing or tightening the spring, always use clean parts and do not use grease.

## Powerline

Check the powerline with 12 mm thick iron bar. If there is no rubber stopper to stop the engine turning when using the throttle, then **Y** must be 1,0 - 1,5 mm bigger than **X**. Note also that due to a smaller clutch, the distance **Z** in your service manual does not exist. It is something else, but the difference is acceptable.

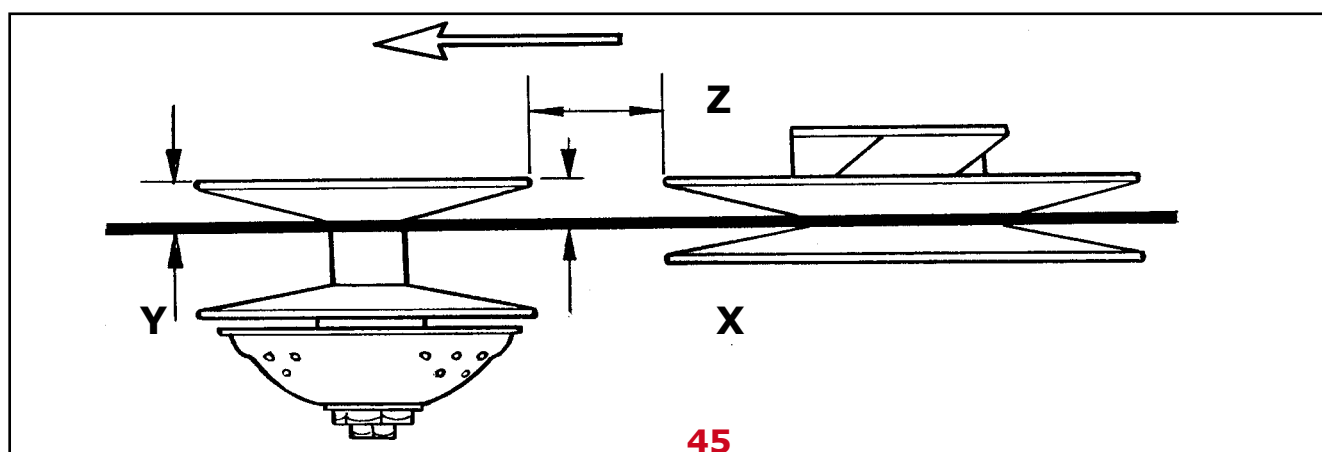

# Arctic Cat

## crankshaft bearings

<b>2-CYL F/C</b>	Years	MGT	CENTER	PTO
340 F/C inj	1987-94	83350A ( DG2555 )	83350A (DG2555 )	83519D x 83519D
440 F/C	1980-06	83519D	83519D x 83519D	83519D x 83519D
370-Z440	1999-08	83519D	83519D x 83519D	83519D x 83519D
440 F/C	1988-00	83519D	83519D x 83519D	83519D x 83519D
440F/C Snopro	2002-03	83519D	83519D x 83519D	OEM 3006-096
500 F/C	Kaikki	83519D x 83519D	83519D x 83519D	83519D x 83519D
570 F/C	2002-05	6306N9C4 /	6306N9C4 x 2	35NQ5528W11
<b>2-CYL L/C</b>				
440 L/C		83519D x 83519D	83519D x 83519D	OEM N/A
440 L/C	1987-89	83519D x 83519D	83A073B x 83A073B	OEM N/A
440 L/C ZR	1995	83A073-9	83A073B x 83A073B	40NQ 6430W1
440 L/C ZR	1996-00	83A073-9	83A073B x 83A073B	40NQ 6430W1
440L/C Snopro	2003-04	306/1DYR1W	83B551A 30mm x 2	40NQ 6430W1S
F-5	2003-07	306/1DYR1W	83B551A 30mm x 2	40NQ 6430W1S
5-600ZR T-	1998-02	83A073-9	83A073B x 83A073B	40NQ 6430W1
530 L/C		83519D	83A073B x 83A073B	OEM N/A
550 L/C	1991-92	83A073-9	83A073A x 83A073B	40NQ 6430W1
550 L/C	1993-05	83A073-9	83A073A x 83A073B	40NQ 6430W1
580 L/C	1993-05	83A073-9	83A073A x 83A073B	40NQ 6430W1
600 ZR	2000-04	6306/4DYR1	83B551A 30mm x 2	40NQ 6430W1
650 L/C W-C	1988-90	83B551A 35mm	83B551A 35mm x 2	OEM N/A
700 L/C	1991-93	83B551A 35mm	83B551A 35mm x 2	40NQ 6430W1
700 L/C	1994-97	83B551A 35mm	83B551A 35mm x 2	40NQ 6430W1
F6-F7	2003-05	22075/1DYR1W	83B551A 35mm x 2	40NQ 6430W1S
800-900 ZR	2000-06	307/1DYR1W10	6307R/1DYR x 2	3208/1DW11CA
<b>3-CYL L/C</b>				
600 L/C ZRT	1995-02	83A073B	6207R9 x 83A073B x2	40NQ 6430W1
800-900 L/C	1993-00	6306/4DYRI	6209/1DRIN X 4	6209/1DRIN X 2
1000 L/C	1998-02	6306/4DYRI	6209/1DRIN X 4	6209/1DRIN X 2

### Part number      Dimensions

Part number 35-	Dimensions	Parts number 35-	Dimensions
22075/1DYR1W	35 X 75 X 23	DG2555	25 X 55 X 15
3208/1DW11CA	40 X 83 X 30	35NQ5528W11	35 X 55 X 28
306/1DYR1W	30 X 75 X 19	40NQ6430WI	40 X 64 X 30
307/1DYR1W10	35 X 83 X 21	40NQ6430W1S	40 X 64 X 30
6209/1DRIN	45 X 90 X 19	83519D	30 X 65 X 16
6207R9	35 X 72 X 17	83A073-9	30 X 72 X 19
6306/4DYR1	30 X 72 X 19	83350A	25 X 55 X 15
6306/N9C4	30 X 72 X 19	83B551A 30 mm	30 X 75 X 17
OEM 3006-096		83B551A 35 mm	35 X 75 X 17

# Rotax = Lynx, Skidoo crankshaft bearings

1-CYL F/C		MGT	CENTER	PTO
247 F/C ELAN	1985-96	83464C ( 6305 C4 )		83464C ( 6305C4 )
253 F/C	1985-92	6206 GPC4		6206 GPC4
277 F/C	1980-84	83464C		6306 PC4
277 F/C	1993-08	6206 C4		6306 PC4
<b>2-CYL F/C</b>				
377-447 Kärjet	1980-81	6207 GPC4	6305 NRC4 x 2	6207 GPC4 x 2
377-447 Nippon D	1982-89	6207 GPC4	6305 NRC4 x 2	6206 GPC4 x 2
377-447 F/C	1990-96	6207 GPC4	6207 GPC4 x 2	6207 GPC4 x 2
377-447 F/C	1997-05	6207 GPC4	6207 GPC4 x 2	6207 PC4 x 2
503 Kärjet	1979-81	6207 GPC4	6305-NRC4 x 2	6206 GPC4 x 2
503 Nippon D	1982-89	6207 GPC4	6305 NRC4 x 6206 GPC4	6206 GPC4 x 2
503 F/C	1990-96	6207 GPC4	6207 GPC4 x 2	6207 GPC4 x 2
503 F/C	1997-03	6207 GPC4	6207 GPC4 x 2	6207 GPC4 x 2
550 Top needle	2003-05	6207 GPC4	6207 PC4 x 6207 PC4	6207 GPC4
640 F/C	1970-82	6306 NRC4	6306 NRC4	6306 NRC4
<b>2-CYL L/C</b>				
440 MXZ-X, 500	2000-05	6206 PC4 x 2	6206 PC4 x 2	6207 PC4 x 2
444 L/C	1977-79	6206 GPC4	6305 NRC4 x 2	6206 GPC4 x 2
454 L/C	1995-98	6206 PC4 x 2	6206 PC4 x 2	6207 PC4 x 2
462 L/C SP-SS	1984-86	6206 GPC4	6305 NRC4 x 6206 GPC4	6206 GPC4 x 2
467 L/C	1985-95	6206 GPC4 x 2	6305 NRC4 x 6206 GPC4	6207 GPC4x 2
494 L/C T-Crank	1996-00	6206 PC4 x 2	6206 PC4 x 2	6207 PC4 x 2
500 L/C	2003	6206 PC4 x 804551	6206 PC4 x 2	FAG x 6207 PC4
532-536-582-583	1985-99	6206 GPC4 x 2	6305 NRC4 x 6206 GPC4	6207 NRC4 x 2
600 L/C C-Seal 63	1999	6206 PC4 x 2	6206 GPC4 x 2	6207 PC4 x 2
600 L/C C-Seal 66	2000-02	6207 PC4 x 2	6206 GPC4 x 2	FAG x 6207 PC4
500SS, 600 C-S 66	2003-07	804551 x 6206 PC4	6206 PC4 x 2	FAG x 6207 PC4
600 MXCX RS	2008	6207 PC4 x 2	6207 PC4 x 2	804662E x 6208 PC4
600 HO SDI Key12	2004-07	FAG x 6207PC4	6207 PC4 x 2	6208X x 804662E
600 HO C-Seal 76	2003-05	FAG x 6207PC4	6207 PC4 x 2	FAG x 6207 PC4
600/593 E-Tec	All	FAG x 6207PC4	6207 PC4 x 2	6208X x 804662E
617-643 L/C	1991-92	6206 GPC4 x 2	6305 NRC4 x 6206 GPC4	6207 GPC4 x 2
670 L/C	1993-97	6206 PC4 x 2	6206 PC4 x 2	6207 GPC4 x 2
670 L/C	1998-99	6207 PC4 x 2	6206 PC4 x 2	6207 PC4 x 2
700 L/C C-Seal 79	1999-00	6207 PC4 x 2	6207 PC4 x 2	6208 PC4 X 2
700 L/C C-Seal 76	2000	6207 PC4 x 2	6207 PC4 x 2	6208 PC4 x 2
700 L/C Mgt seal	2001-02	FAG x 6207PC4	6207 PC4 x 2	6208 PC4 x 2
700 L/C C-Seal 76	2003-05	FAG x 6207PC4	6207 PC4 x 2	6208 PC4 x 804662E
800 L/C	2000-03	FAG x 6207PC4	6207 PC4 x 2	6208-PC4 X 2
800 L/C HO, R,	2003-07	FAG x 6207PC4	6207 PC4 x 2	6208X x 804662E
1000 L/ HO	2005-07	804662E x 2	6208 PC4 x 2	804662E x 2
<b>3-CYL L/C</b>				
600 L/C	1995	6208-PC4	6206 PC4 x 4	6208 PC4 x 2
600 L/C	1996-97	6208-PC4	6206 PC4 x 4	6208 PC4 x 2
600-700 L/C CK3	1998-00	6208-PC4	6206 PC4 x 4	6208 PC4 x 2
779 L/C	1993-96	6208-PC4	6207 GPC4x 4	6208 PC4 x 2
809 L/C	1997-03	6208-PC4	6207 PC4 x 4	6208 PC4 x 2

# Rotax

## Part number

## Dimensions

Part number 35-	Dimensions	Parts number 35-	Dimensions
6305 C4 = 83464 C	25 X 62 X 17	6207 C4	35 X 72 X 17
6305 NRC4	25 X 62 X 17	6207 PC4	35 X 72 X 17
6306 NRC4	30 X 72 X 19	6207 GPC4	35 X 72 X 17
6206 C4	30 X 62 X 16	804551 = 6206 GSPC4	30 X 62 X 18/19
6206 PC4	30 X 62 X 16	804662E = 6208 GSPC4	40 X 80 X 21
6206 GPC4	30 X 62 X 16	6208 PC4	40 X 80 X 18
FAG = 804661BL178	35 X 72 X 17/18	6208X = 6208X28YR1N	40 X 80 X 23
FAG = 6207 GSPC4	35 X 72 X 17/18	6208 GSPC4	40 X 80 X 21

# Yamaha

## crankshaft bearings

1-CYL F/C		MGT	CENTER	PTO
250 ET		6206 C4		6306 NRC4
250 BRAVO		6305 H/INDY		6306 N9C4
2-CYL F/C				
300-340 F/C ET		83464-C	83548D-9	6306 N9C4
400-410 F/C		83464-C	83548D-9 x 83548D-9	OEM N/A
440 SS		83548D9		DG3278JJSO x 2
485 F/C	1984-98	DG3268B	DG3268-B x DG3268-B	83A779 x 2
500 F/C	1999-02	DG3268B		83A779 x 2
535-540 F/C VK		83548D9	83548D-9 x 83548D-9	DG3278JJSO x 2
2-CYL L/C				
500-570-600cc	1987-96	83B207		
500-600 L/C	1997-	83B207		
3-CYL L/C				
700 L/C SX	1997	62/32GPC4 x 2	62/32GPC4 x 2 x OEM N/A	OEM N/A
600-700 L/C SX	1998-06	OEM N/A	OEM N/A	OEM N/A
600-700 L/C SRX	1998-99	OEM N/A	OEM N/A	OEM N/A
600-700 L/C SRX	2000-02	OEM N/A	OEM N/A	OEM N/A
700 L/C VIPER	2002-06	OEM N/A	OEM N/A	OEM N/A
4-CYL L/C		LEFT	CENTRE-GEAR CENTRE	RIGHT
750 / 8AX-11401	1992-94	6206PC4	6206PC4 x 4 x 6305GPC4	OEM N/A
750 / 8AX-11402	1992-04	6206PC4	6206PC4 x 4 x 6305GPC4	83464C
800 / 8BU-11401	1995-97	6206PC4	6206PC4 x 4 x 6305GPC4	OEM N/A
800 / 8BU-11402	1995-97	6206PC4	6206PC4 x 4 x 6305GPC4	OEM N/A

## Part number

## Dimensions

Part number 35-	Dimensions		Parts number 35-	Dimensions
6206 C4	30 X 62 X 16		83464C	25 X 62 X 17
6206 PC4	30 X 62 X 16		83A779	32 X 78 X 19
6305 H/INDY	25 X 68 X 17		83548D-9	32 X 62 X 16
6306 NRC4	30 X 75 X 19		83B207	32 X 72 X 30
6206 N9C4	30 X 72 X 19		DG3268-B	32 X 68 X 16
62/32 GPC4	32 X 65 X 17		DG3278JJSO	32 X 78 X 16,5

# Polaris crankshaft bearings

1-CYL F/C		MGT	CENTER X 2	PTO
250 F/C	1985-95	6206 C4		6206 C4 x 2
2-CYL F/C				
340 F/C Injection	Kaikki	6206 C4	6007 PC4 x 2	6206 GPC4 x 6206 PC4
440-500 F/C		6206 PC4	6206 PC4 x 2	6206 GPC4 x 6206 PC4
440 XCF-550 F/C	1998-07	5206 S9	6206 PC4 x 2	6207 GPC4 x 6207 PC4
2-CYL L/C				
440-500L/C		6206 PC4	6206 PC4 x 2	6206 GPC4 x 6206 PC4
440 L/C XCR only	1994-95	6206 PC4	6206 PC4 x 2	6206 GPC4 x 6206 PC4
440 L/C XCR	1996-97	6206 PC4	6206 PC4 x 2	62/32 PC4 x 62/32 GPC4
500 L/C	1996-00	6206 PC4	6206 PC4 x 2	62/32 PC4 x 62/32 GPC4
500 LC	2000-10	5206 S9	6206 PC4 x 2	62/32 PC4 x 62/32 GPC4
440 LC PRO X	1998-03	6207 PC4	DG3572201C4	DG3572201C4 x 6207PC4
440 LC PRO X	2004-07	6207 PC4	DG3572201C4	DG3572201C4 x 6207PC4
500-600 L/C USA	1998-03	6207 PC4	DG3572201C4	6207/9BA9T x 6207 PC4
500-600 L/C PRO X	2004-09	6207 PC4	DG3572201C4	6207/9BA9T x 6207 PC4
600-700 L/C	1997-98	6207 PC4 x 2	6207 PC4 x 2	6207 GPC4 x 6207 PC4
600 HO	2007-09	DG3572201C4	DG3572201C4	6207/9BA9T x 2
600 IQ	2008	DG3572201C4	DG3572201C4	6207/9BA9T x DG3572201C4
700 LC Dragon-RMK	2008-10	DG3572201C4	DG3572201C4	6207/9BA9T X 2
600-700 L/C	1999-05	6207 PC4 x 2	6207 GPC4 x 2	6207/9BA9T x 6207 PC4
600-700 L/C HD pto	1999-05	6207 PC4 x 2	6207 GPC4 x 2	5207 S9C4 x 6207 PC4
700 L/C Classic	2006-10	6207 PC4 DG3572201C4	6207 GPC4 x 2	5208C4 x 2
700 L/C Frontier 4-t	2002-04			6207/9BA9T x 6207 GPC4
800 L/C USA	2000-05	6207 PC4 x 2	6207 GPC4 x 2	6207/9BA9T x 6207 PC4
800 L/C Heavy duty	2000-05	6207 PC4 x 2	6207 GPC4 x 2	5207 S9C4 x 6207 PC4
900 L/C	2005-06	6207 PC4 x 2	6207 GPC4 x 2	5208C4 x 2
3- CYL L/C				
580 L/C mono block	1992-94	6206 PC4	6206 PC4 x 4	6206 GPC4 x 6206 PC4
600 L/C mono block	1995-97	5206 S9	6206 PC4 x 4	6206 GPC4 x 6206 PC4
600 L/C oil jet	1997-00	5206 S9	6206 PC4 x 4	6206 GPC4 x 5206S9
600 SP-680 L/C	1996	35BG06 S9	6007 PC4 x 4	6207 GPC4 x 6207 PC4
650 L/C CARB-RXL	1985-98	5206-S9	6206 PC4 x 2	6206 GPC4 x 5206S9
600-680-700 XRC	1997-98	35BG06 S9	6007 PC4 x 4	6207 PC4 x 6207 GPC4
750-800 L/C Storm	1993-98	6207 PC4 x 2	6207 PC4 x 4	6307 GPC4 x 6307 PC4
700-800 XCR	1999-03	35BG06 S9	6007 PC4 x 4	6207 GPC4 x 6207 PC4

Part number 35-	Dimensions		Parts number 35-	Dimensions
6206 C4	30 X 62 X 16		5206 S9	30 X 62 X 23,8
6206 PC4	30 X 62 X 16		5207 S9C4	35 X 72 X 27
6206 GPC4	30 X 62 X 16		5208 C4	40 X 80 X 30,2
6207 PC4	35 X 72 X 17		62/32 GPC4	32 X 65 X 17
6207 GPC4	35 X 72 X 17		35BG06 S9	35 X 62 X 23,8
6207/9BA9T	35 X 72 X 24		DG3572201C4	35 X 78 X 20
6307 PC4	35 X 80 X 21	<b>49</b>	6307 GPC4	35 X 80 X 21

# Crankshaft Bearing Grease

**35-900** Grease 300 g Should be used when the PTO  
**35-901** Grease 50 g and / or MGT bearing is an  
 enclosed space.



## Needle Cage

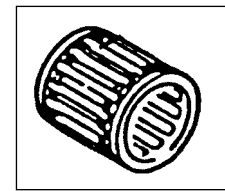

<b>35-500</b>	19 x 23 x 24 ( 1414 )	<b>35-513</b>	16 x 20 x 20
<b>35-501</b>	16 x 20 x 22 ( 1404 )	<b>35-514</b>	15 x 19 x 20
<b>35-502</b>	16 x 21 x 20 ( 1407 )	<b>35-515</b>	16 x 22 x 17
<b>35-503</b>	18 x 23 x 22 ( 1413 )	<b>35-517</b>	20 x 24 x 30
<b>35-505</b>	18 x 22 x 22 ( 1410 )	<b>35-520</b>	18 x 23 x 21
<b>35-506</b>	16 x 20 x 24 ( 1406 )	<b>35-521</b>	20 x 25 x 24
<b>35-508</b>	20 x 24 x 19 ( 1415 )	<b>35-522</b>	16 x 20 x 22,5
<b>35-510</b>	18 x 22 x 28 ( 1411 )	<b>35-523</b>	20 x 26 x 24
<b>35-512</b>	20 x 24 x 24 ( 1412 )	<b>35-524</b>	20 x 24 x 22,7
		<b>35-525</b>	16 x 20 x 21,7

## Oil seals

### Arctic Cat

09-14600	30x62x10
09-14603	30x65x9/11
09-14605	35x75x9/11
09-14613	25x55x9
09-14616	35x75x8/10
09-14617	35x55x7

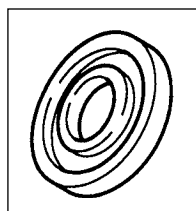

### Ski-doo

09-113	30x42x7
09-11301	32x42x7
09-116	25x62x10
09-118	25x41,55x10
09-122	35x62x10
09-125	25x52x7/7,5
09-16002	25x62x63,5x5x6
09-16003	30x62x63,5x5x6
09-165	35x72x7/8
09-167	30x62x7/8
09-168	28x38x7
09-169	30x47x7
09-170	40x80x7

### Sachs

09-108	30x47x8
09-114	25x35x7,9

### Polaris

09-140	30x62x8
09-14102	30x44x7
09-14103	30x62x8/11
09-14104	30x44x5,7
09-14202	30x62/63,7x7
09-14619	40x64x8

### Kohler

09-104	25x42x10/11
09-113	30x42x7

### Yamaha

09-131	25x48x8
09-132	30x72x8
09-135	32x78x10x13
09-137	32x78x9,5
09-143	32x48x10
09-14301	35x80x6
09-14302	25/32x78x8
09-14303	25/32x48x8
09-14306	23/35x58x12
09-14311	32x48x9,2
09-14313	32x48x10

## Arctic Cat



07-100 01  
JAG 87-91, 0109-926

## Polaris:



07-100 05  
VM 38 SS, 3083171

## Rotax



07-100 10  
VM 34 straight



07-100 13  
SKID. VM 30, 32, 34 HD



07-100 22  
VM34,79-84, 570.1339.00

## Carburetor flanges



VM 30, 32, 34 HD  
07-100 13



07-100 06  
VM 32, 34, HR, 3083306



07-100 11  
VM 34, 570.1262.00



07-100 20  
TUNDRA VM 34



07-100 23  
VM 40, 44, 570.038.200

## Yamaha



07-100 13  
VM 30, 32, 34 HD



07-100 13  
VM 30, 32, 34 HD



07-100 12  
VM 570.1261.00



07-10021 MX 85-92

Carburetor flanges suitability are shown on

[www.teolehtimaki.fi](http://www.teolehtimaki.fi)

and there you open the correct page. At the same time you can find other replacement parts

# Engine gaskets, professional

Number	Arctic Cat year gasket 840-old p/n	Piston
710-060A	FS CAT 440 FC, 80- , 09-696, 840-80607	09-696
710-063	FS CAT 500 CC, FC, 78-85, 09-693	09-693
710-063B	FC CAT 340 FC, 77- , 09-692, 840-80588	09-692
710-063C	FS CAT 500 EL T. 6000, 80-85, 09-694	09-694
710-063D	FS CAT 530 LC, 86-91, 09-699, 840-80632	09-699
710-063E	FS CAT 500 FC, 86-90, 09-691, 840-8061	09-691
710-179	FS CAT 440 LC 90-00, 09-695, 840-8181	09-695
710-180	FS CAT 700 LC, 91-96, 09-682, 840-8180	09-682
710-189	FS CAT 550+580 91- , 09-681+683+687, -8182	09-681-683
710-193	FS CAT 800 3-CYL. 95-01, 09-602	09-602
710-216	FS CAT 594, 3-CYL. 95-02, 09-601	09-601
710-227	FS CAT ZR500, - 98, 09-605	09-605
710-262	FS CAT 800 2-CYL. 01- , 09-611	09-611
710-266	FS CAT ZL600, 01-02, 09-609	09-609
710-267	FS CAT ZR700, 99-00,	09-
710-270	FS CAT ZL 570	09-
	<b>Rotax Ski-Doo Lynx Trapper Nordik</b>	
710-022X	FS ROTAX 640 74- , 09-762-763	09-762-763
710-023A	FS ROTAX 377, -89, 09-751	09-751
710-023C	FS ROTAX 377, 90-95, 09-751, 841-80238	09-751
710-024	FS ROTAX 250, 71-96, 09-740, ELAN, 8024	09-740
710-025	FS ROTAX 440 ( 467 ) 71- , 09-761	09-761
710-026	FS ROTAX 340 76- , 09-747-748	09-747-748
710-119	FS ROTAX 250 TWIN, 73- , 09-745	09-745
710-162A	FS ROTAX 503 -95, 09-741, 841-8162	09-741
710-162B	FS ROTAX 503 -90, 09-741 , 841-8162	09-741
710-162C	FS ROTAX 447 -95, 09-752, 840-8124	09-752
710-163A	FS ROTAX 454 BLIZZ, 79- , 09-760	09-760
710-164	FS ROTAX 253, 85-93, 09-741, 841-8123	09-741
710-165	FS ROTAX 521, 09-741	09-741
710-165C	FS ROTAX 467, -95, 09-761	09-761
710-177	FS ROTAX 536 , 89- , 09-741	09-741
710-178C	FS ROTAX 583 -95, 09-772	09-772
710-194	FS ROTAX 582, -95 , 09-772	09-772
710-195	FS ROTAX 277, 1996- 09-741	09-741
710-196	FS ROTAX 503 FC 95- , 09-741, O-RENGAS	09-741
710-197	FS ROTAX 670, 93-95, 09-773	09-773
710-203	FS ROTAX 467 , 94-96, 09-761	09-761
710-210	FS ROTAX 380, 440, 1996- , 09-751, 09-752, O-	09-751-752
710-211	FS ROTAX 454, 95-97, 09-760	09-760
710-212	FS ROTAX 494 LC, 96-01, 09-780	09-780
710-213	FS ROTAX 599, 3-CYL. 09-774	09-774
710-214	FS ROTAX 599, 3-CYL. 09-774	09-774
710-215	FS ROTAX 670, 95- , 09-773	09-773
710-221	FS ROTAX 800 97-01, 09-782	09-782
710-222	FS ROTAX 700, 97-00, 09-781	09-781
710-235	FS ROTAX 600 , 99- , 09-785	09-785

# Wössner Hi-Performance Forged Pistons

Model	piston number	cyl	displ. cc	bore	over sizes	Kimpex number
<b>Arctic Cat</b>						
Z440 1995-98, Jag 440	09-7001	2	431	65.00	std	09-696
Bearcat 440 1993-00						
ZL/ZR 500, Powder Spec -00	09-7004	2	497	71,00	std	
Bearcat 550 1995-02	09-7005	2	550	73,40	std	09-683
ZL 550, ESR 2001-2003						
EXT Triple 600 1996-97	09-7006	3	594	66,50	std	09-601
ZRT 600 1996-00						
ZL/ZR 600, EFI 1998-99	09-7007	2	599	78,00	std	
Powder Special 1998-00						
Mountain CAAt 2001-04	09-7008	2	599	78,00	std	09-609
Pantera EFI 2002-05						
ZL/ZR 600, R 600, 2000-03						
Crossfire 7 -06, F7 2003-06	09-7009	2	698	79,70	std	09-657
MCat 700, WildC 91-00	09-7010	2	699	81,00	std	09-682
ZR 700, ZL 700 1994-00						
MCat, ZL, ZR 800, 2001-04	09-7011	2	785	81,00	std	09-611
ZRT 800, Pantera 1995-01	09-7012	3	794	72,00	std	09-602
Thunder Cat 1000, 1998-02	09-7013	3	1000	81,00	std	09-612
<b>Polaris</b>						
Fuji Motor	09-7015	2	544	73,00	std	09-727
550 Classic 2003-04						
Indy 550 models 1999-2009						
Liberty Motor	09-7016	2	593	74,50	std	09-721
600 RMK 1998-01,						
Indy 600 CX, SP 1998-01						
Liberty Motor	09-7017	2	600	77,24	std	09-728
600 Classic, Edge Tour 00-06						
600 IQ, RMK, ProX, 02-09						
Indy 600 XCSP Ves 00-05						
Liberty Motor	09-7018	2	700	81,00	std	09-722
700 Class, ProX, RMK, 97-07						
XC700, SP, Switchb. 1998-05						
Liberty Motor	09-7019	2	784	85,00	std	09-730
800 Clas. Edge, ProX 03-05						
800 RMK, SKS, XCSP, 01-05						
Liberty Motor	09-7020	2	866	83,00	std	
900 Fusion, RMK, Sw. 05-06						

# Wössner Hi-Performance Forged Pistons

Model	piston number	cyl	displ. cc	bore	over sizes	Kimpex number
<b>Rotax = Skidoo, Lynx</b>						
593 H.O Engine Type	09-7021	2	594	72,00	std	09-776
Exp. TUV 2005-10, GSX, GTX						
GT 600 Sport 2003, Legend						
Legend 600 Sdi, SE600 2004						
MXZ Blizz, Adr, 2003-09						
Renegade 600, X, 2003-09						
MXZ Rev, Trail, X, 2003-05						
Scandic 600 SUV 2008						
Rotax 593/600 E-Tec						
793 Engine Type	09-7022	2	800	82,00	std	09-778
GT 800 Se, Legend 2003,						
All PTEK models 2007						
GTX, GTX Ltd, 2005-06						
MXZ 800, Rev, 200-03						
MXZ 800 Adr, X, 2005-06						
Summit 800, HM, HO, 00-06						
800R Engine type	09-7023	2	800	82,00	std	
GSX Ltd 800R 2008						
MXZ 800R all, 2008-09						
Renegade 800R, all 2008-09						
Summit 800R all, 2008-09						
494 Engine type	09-7028	2	494	69,50	std	09-780
Formula 500 LC 2000						
Formula DL, Z 500, 1998-00						
GT 500, 1998-01						
MXZ 500, Trail, 1998-01						
Skandic 500 1997-00						
Touring 500 LC, 2000						
<b>Yamaha</b>						
SX 500R, 00-01, VT 1999-01	09-7024	2	493	68,00	std	09-829
V-max 500 1994-01						
Mountain Max 600, 1998-99	09-7025	2	598	74,80	std	09-826
V-Max 600, 1994-99, VT -98						
SX 700R 2000-01	09-7026	3	698	70,50	std	
Venture 1998-03						
V-Max, MMax 1997-04						
SRX 700 1998-02	09-7027	3	696	69,00	std	09-831
Mountain Max 700 1998						

# Engine gaskets, professional

Number	Rotax Ski-Doo Lynx Trapper Nordik	Piston
710-255	FS ROTAX 700, 00-02, 09-783	09-783
710-256	FS ROTAX 493, 00-05, 09-784	09-784
710-259	FS ROTAX 593 RAVE, 09-785	09-785
710-261	FS ROTAX 800 , 02-03	
710-277	FS, ROTAX 552, 03---, 09-779	09-779
710-278	FS ROTAX 594 HO 03-05, 09-776	09-776
	<b>Polaris</b>	
710-069	FS POL 244, ALL, 09-700, 840-8069	09-700
710-070	FS POL 250 74-78, 09-702	09-702
710-071	FS POL 250, 76-89, 09-703	09-703
710-073	FS POL 340 77-81, 09-708	09-708
710-075	FS POL 340 73-82, 09-706	09-706
710-078	FS POL 440 75-81, 09-704	09-704
710-079	FS POL 440 75-80, 09-705	09-705
710-109C	FS POL 400 2-CYL. 84-91, 09-707	09-707
710-110	FS POL 600 3-CYL. 84-87, 09-707	09-707
710-110A	FS POL 440 82-99, 09-710	09-710
710-110C	FS POL 488 FC 86-99, 09-712, 840-81108	09-712
710-173	FS POL 340, 86-93, 09-709 JA 94-, 09-717	09-709
710-181A	FS POL 650 88-97, 09-713, 840-8187	09-713
710-185A	FS POL 488 LC, 89-02, 09-711, 840-8188	09-711
710-186	FS POL 440 FC 91-99, 09-710	09-710
710-191	FS POL 580 93-94 , 09-714	09-714
710-204	FS POL. 94-97, 09-716	09-716
710-205	FS POL 600 3-CYL. 95-00, 09-716	09-716
710-206	FS POL 679 3-CYL. 96-97 , 09-718	09-718
710-231	FS POL. XC700, 98-01, 09-721	09-721
710-238	FS POL FC 550, 99- , 09-727	09-727
	<b>Yamaha</b>	
710-027A	FS YAMAHA 250 BRAVO 84- , 09-800	09-800
710-140A	FS YAMAHA 535, 83-91, 09-816	09-816
710-142	FS YAMAHA EX 340 81-88, 09-802	09-802
710-142C	FS YAMAHA 340 , 89- , 09-802	09-802
710-146	FS YAMAHA EX 440 76-81, 09-806	09-806
710-147C	FS YAMAHA SS440 80-83, 09-807	09-807
710-167	FS YAMAHA 535 CC SRV 82-90, 09-808	09-808
710-167A	FS YAMAHA 540,540 SRV 85-90	09-808
710-168	FS YAMAHA PZ 480 84-90, 09-813	09-813
710-168B	FS YAMAHA 485 CC, -07, 09-813	09-813
710-171	FS YAMAHA 570 -90, 09-817	09-817
710-171A	FS YAMAHA 570 CC, 91-, 09-817	09-817
710-182	FS YAMAHA 535 VIKING 92- 07, 09-808	09-808
710-200	FS YAMAHA 494 CC 94-96, 09-825	09-825
710-201	FS YAMAHA 598 CC 94-95, 09-826	09-826
710-239	FS YAMAHA 485 CC, ( 500 ) -07 09-813	09-813

# Arctic Cat Pistons Gaskets Needle cage Oil seals

Arctic Cat	dia mm	ccm/cm3	gasket	needle cage	oil seal magn	oil seal
EXT 600 Tr. 97-98 EXT 600 Triple Touring 1998 Powder EXT 600 1997-98 ZRT 600 1995-98						
<b>09-601</b>	66,50	<b>594 3-syl</b>	710-216	35-503	09-14618	09-14619
Pantera 800 1998-01 ZRT 800 1995-01						
<b>09-602</b>	72,00	<b>794 3-syl</b>	710-217	35-523	09-14618	09-14619
ZL 500 EFI 1998-01; ZR 500, ERSI 1998-01; Powder SP 500 EFI 1999-01						
<b>09-679</b>	71,00	<b>497 2-syl</b>		35-523	09-14618	09-14619
EXT 580 MC; EXT 580 EFI MC 1993-97; 580 Powder SP 1995-97; ZR 580 1993-97; Pantera 580 1995-97						
<b>09-681</b>	75,40	<b>580 2-syl</b>	710-189	35-523	09-14618	09-14619
Wildcat 700 MC. EFI 1991-96, ZR 700 1995, ZL 700 2000, ZR 700 1999-00						
<b>09-682</b>	81,00	<b>699 2-syl</b>	710-190	35-523	09-14617	09-14619
EXT special 1991-92; EXT Mountain Cat 1991-92; EXT 550 EFI, EFI Mtn Cat 1993-94 Bear Cat 550WT 2000- Pantera 550 2002-05, Panther 550 2000-01, ZL 550 ESR 2000-03						
<b>09-683 (687)</b>	73,40	<b>550 2-syl</b>	710-189	35-523	09-14618	09-14619
Wildcat 650 1988-90, Mountain Cat 1990						
<b>09-684</b>	78,00	<b>650 2-syl</b>		35-523		
Panther, Puma, Cheetah, Pantera 1971-1975 Lynx II -74Jag 340 -75						
<b>09-685</b>	60,00	<b>339 2-syl</b>		35-525		
Bearcat 550 1995-98; Cheetah 550 1994; Cougar 550 1995-98; EXT 550, EFI 1993-98; Pantera 550 1993-94; Panther 550 1997-98; Prowler 550 1995						
<b>09-687</b>	73,40	<b>550 2-syl</b>	710-189	35-523	09-14618	09-14619
El Tigre 440 Z 1975-77; <b>Kawasaki Intriguer, Intruder, Invader; Drifter 440 1978-81</b>						
<b>09-689</b>	68,00	<b>440 2-syl</b>		35-522	09-14603	09-14603
Cheetah FC, Cougar 1986-90						
<b>09-691</b>	70,00	<b>500 2-syl</b>	710-063E	35-503	09-14603	09-14603
Bearcat 340 1995-01; Cheetah 340 1994; Jag 340 1976-77, 1987-90; Jag 3000 FA, FC 1978-80 Jag Deluxe 1987-90; Jag Mountain Cat 1990-91; Jag 340 DeLuxe 1998-99; Panther 340 1998-01 Trail Cat 3000 FC 1980; Manx, Manx Deluxe 1991-93; Manx Mountain Cat 1992-93; Puma DeLuxe 1994-97						
<b>09-692</b>	60,00	<b>339 2-syl</b>	710-063B	35-502	09-14603	09-14603
Cheetah 5000 1976-78; El Tigre 500 1976; El Tigre 5000 1977-81; Pantera 5000 1976-81; Panther 500 1976Cougar Spec. Edition 1985; Panther 1986-88; Pantera el. 1980; Manx 2000S 1977-80, El Tigre 6000 LC 1980-85						
<b>09-693</b>	70,00	<b>500 2-syl</b>	710-063	35-503	09-14603	09-14603
El Tigre 6000 LC 1980-85						
<b>09-694</b>	70,00	<b>500 2-syl</b>	710-063C	35-503	09-14603	09-14603
El Tigre 6000 LC 1978-79; El Tigre Cross Country 1979; Pantera LC 1985-92; El Tigre 5000 LC 1987Jag 440 LC 1987; Panther 440 LC 1996; ZL 440 1997-99; Prowler 1990-94; Cheetah Touring 1991-93; Cougar 1991-94.						
<b>09-695</b>	68,00	<b>440 2-syl</b>	710-063A	35-503	09-14603	09-14603
Bearcat 440 1995-01; Cheetah 440 1994; Panther 4000 FC 1980-81; Trail Cat 4000 FC 1980-81; Jag 4000 FC 1980-81; Jag AFS LT 1991-93; Jag FC 1985-87; Jag 440 DeLuxe 1988-99 Jag 440 Z 1991-96; Panther DeLuxe 440 1984-01; Z 440 ES 1990-01; Super Jag 1991-92						
<b>09-696</b>	65,00	<b>431 2-syl</b>	710-060A	35-502	09-14603	09-14613
Cheetah LC 1986-89; El Tigre 6000 1986-89; El Tigre EXT 1989-91; El Tigre Ext Mountain Cat 1990						
<b>09-699</b>	72,00	<b>529 2-syl</b>	710-063D	35-503	09-14603	09-14605

## Piston rings

MOS 2 surface

## Gudgeon pin

Rotax 503-253

10-741-00  
10-741-01  
10-741-02  
10-741-04

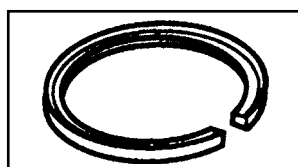

Rotax 377

10-751-00  
10-751-01  
10-751-02  
10-751-04

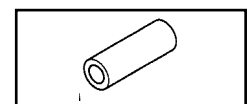

11-741  
11-751

# Skidoo, Rotax

## Pistons Gaskets Needle cage Oil seals

Ski-Doo	dia mm	ccm/cm3	gasket	needle cage	oil seal magn	oil seal
Spirit 250 1976-78; Elan 250 E 1971-78						
<b>09-740</b>	69,00	<b>247 1-syl</b>		35-505	09-118	09-118
<b>09-740-02</b>	69,50					
<b>09-740-04</b>	70,00					
Spirit 250 1979-83; Elan 250 1979-96						
<b>09-740-02</b>	69,50	<b>250 1-syl</b>		35-505	09-118	09-118
<b>09-740-04</b>	70,00					
Rotax 253, 277, 503,521,536 Lynx, Nordik, Ockelbo, Skidoo, Trapper, Winha, Freestyle, Tundra						
<b>09-741</b>	72,00	<b>253 1-syl</b>	<b>check</b>	35-505	09-126	09-146
<b>09-741-01</b>	72,25	<b>277 1-syl</b>	<b>the gaskets</b>	35-505	09-168	09-169
<b>09-741-02</b>	72,50	<b>503 2-syl</b>	<b>behind the</b>	35-505	09-165	09-167
<b>09-741-04</b>	73,00	<b>521 2-syl</b>	<b>name of the</b>	35-505	09-167	09-165
<b>09-741-06</b>	73,50	<b>536 2-syl</b>	<b>snowmobile</b>	35-505	09-167	09-165
Olympic 320, 320E 1969; Olympic 300, S, M, 1971-77						
<b>09-742</b>	76,00	<b>319 1-syl</b>		35-505	09-118	09-118
<b>09-742-02</b>	76,50					
Elan 250 1973-79						
<b>09-745</b>	54,00	<b>247 2-syl</b>	710-119	35-514	09-118	09-118
<b>09-745-02</b>	54,50					
Olympic 335 1969-72; Skandic 1970-73						
<b>09-746</b>	78,00	<b>335 1-syl</b>		35-505	09-118	09-118
<b>09-746-02</b>	78,50					
TNT 340, 1972-76; Olympic 340, E 1975-79; Everest 340, E 1977-79; Futura 340 1975; Nuvik 340, E 76-79						
<b>09-747</b>	59,50 left	<b>339 2-syl</b>		35-505	09-167	09-167
<b>09-747-02</b>	60,00 left					
<b>09-747-04</b>	60,50 vasen					
<b>09-748</b>	59,50 right	<b>339 2-syl</b>		35-505		
<b>09-748-02</b>	60,00 right					
<b>09-748-04</b>	60,50 oikea					
Blizzard 6500 Plus, 7500 Plus, Cross Country 1978-81; Super Sonic 1979-81						
<b>09-750</b>	59,50	<b>339 2-syl</b>		35-505	09-165	09-167
<b>09-750-02</b>	60,00					
Rotax 377 ; Lynx, Nordik, Ockelbo, Skidoo, Trapper, Winha						
<b>09-751</b>	62,00	<b>377 2-syl</b>	<b>Katso</b>	35-505	09-165	09-167
<b>09-751-01</b>	62,25		<b>tiiviste</b>			
<b>09-751-02</b>	62,50		<b>kelkka-</b>			
<b>09-751-04</b>	63,00		<b>kohtaisesta</b>			
<b>09-751-06</b>	63,50		<b>kohtaisesta</b>			
Rotax 447; Lynx, Ockelbo, Skidoo, Trapper, Scandic 440 LT 2001-07, MXZ 440 1999-01, TOUR. E 1999-						
<b>09-752</b>	67,50	<b>447 2-syl</b>	710-162C	35-505	09-165	09-167
<b>09-752-01</b>	67,75					
<b>09-752-02</b>	68,00					
<b>09-752-04</b>	68,25					
Everest 440 FC 1974-79; TNT 440 FC 1975-78; Olympic 1977; Futura 440 1975-79; Nuvik 440 1977						
<b>09-758</b>	67,5 left	<b>436,6 2-syl</b>		35-505	09-122	09-116
<b>09-758-02</b>	68,00					
<b>09-759</b>	67,5 right	<b>436,6 2-syl</b>		35-505	09-167	09-167
<b>09-759-02</b>	68,00					

<b>Ski-Doo</b>	<b>dia mm</b>	<b>ccm/cm3</b>	<b>gasket</b>	<b>needle cage</b>	<b>oil seal magn</b>	<b>oil seal</b>
Blizzard 9500 1979-82; Ultra Sonic 1980-82						
<b>09-760</b>	67,50	<b>436,6 2-syl</b>	710-163A	35-505	09-167	09-167
<b>09-760-01</b>	67,75					
<b>09-760-02</b>	68,00					
<b>09-760-04</b>	68,50					
Rotax 444, 467; Elite 450 LC 1978-79; Everest 444 LC 1978-79; Everest 464 LC 1980-83; SS-25 1984						
Grand Tour. 470 1995; Formula SS 1985; Formula St 1994; Formula SP 1985-86; Formula MX, LT,						
XTC 1985-95 Formula MXZ 1993-94; Safari GLX, LC, LCE 1990-92; Summit 470 1994-95						
<b>09-761</b>	69,50	<b>436,6 2-syl</b>	710-025, -71-	35-505	09-167	09-167
<b>09-761-01</b>	69,75					
<b>09-761-02</b>	70,00	<b>462,8 2-syl</b>	710-165C, -95	35-505	09-167	09-165
<b>09-761-04</b>	70,50		<b>MOS 2 surface</b>			
Alpine 640 1969-82; Nordic 640 1970-74; TNT 640 1971-72; Valmont 1971-72						
<b>09-762</b>	76,00 left	<b>635 2-syl</b>		35-505	09-103	09-103
<b>09-762-02</b>	76,50					
<b>09-762-04</b>	77,00					
<b>09-763</b>	76,00 right	<b>635 2-syl</b>		35-505		
<b>09-763-02</b>	76,50					
<b>09-763-04</b>	77,00					
Rotax 583, 621; F Mach 1, XTC 1989-92; F Plus, E, XTC, X 1992-93; F Plus EFI 1993-94;						
F GT 580 1993-96; F STX 1994-96; Summit 1994-96; F Z 1994-96						
<b>09-772</b>	76,00	<b>583 2-syl</b>	710-178C, 583	35-505	09-167	09-165
<b>09-772-01</b>	76,25					
<b>09-772-02</b>	76,50	<b>617 2-syl</b>	710-194, 582			
<b>09-772-03</b>	76,75					
<b>09-772-04</b>	77,00					
Rotax 670; Mach 1 X 1993; Mach 1 1993-96; MXZ 670 1996-99; GT SE 1994-96;						
F SS 670 1995-96; Summit 670						
<b>09-773</b>	78,00	<b>669 2-syl</b>	710-215	35-524	09-167	09-165
<b>09-773-01</b>	78,25					
<b>09-773-02</b>	78,50					
<b>09-773-04</b>	79,00		<b>MOS 2 surface</b>			
Formula 3 600 1995-97						
<b>09-774</b>	64,50	<b>600 3-syl</b>		35-503		09-165
Rotax 550 fan 2003-						
<b>09-779</b>	75,86	<b>550 2-syl</b>	<b>710-277</b>	35-524	09-165	09-165
<b>09-779-01</b>	76,11					
<b>09-779-02</b>	76,36					
<b>09-779-04</b>	76,86					
Rotax 500, 780; F Z 500 1999; F 500, DLX, SLS 1996-00; GT 500 1996-99; Mach Z 780 1993-97;						
MXZ 500 98-Scandic WT LC 1999-00; Summit 500 1996-99; Touring 500 LC 2000						
<b>09-780</b>	69,50	<b>500 2-syl</b>	710-212	35-505		09-165
<b>09-780-02</b>	70,00	<b>779 3-syl</b>				
Rotax 700; F 3 700 1998-00; GT 700 1998-00; GT SE 1997-98; Mach 1 700 1997-00						
<b>09-781</b>	69,80	<b>699 3-syl</b>	710-222	35-503		09-170
Mach Z 800 1997-99; F 3 800 1999, Mach Z 800 1997-2002,						
<b>09-782</b>	70,50	<b>796 3-syl</b>	710-221	35-503	09-170	09-170
Formula 700, Legend 700, MXZ 700 Summit 700 2000-2002						
<b>09-783</b>	78,00	<b>700 2-syl</b>	710-255			

# Skidoo, Rotax

# Pistons Gaskets Needle cage Oil seals

Formula600 1999-01, Formula 600 GS 2001, Formula Z 1999-00, GT 600 1999-01, MXZ 600 1999-02

Scandik 600 WT L/C 2001-02, Summit 600 1999-01, GT 600 GS, SE, Sport, Legend 600 2002

MXZ 600 Adr., Renegade, Sport, Trail, RER Sport, Sport 2002, Lynx 600 L/C models

<b>09-785</b>	76,00	<b>597 2-syl</b>	<b>710-259</b>			
<b>09-785-02</b>	76,50					

# Polaris Pistons Gaskets Needle cage Oil seals

<b>Polaris</b>	<b>dia mm</b>	<b>ccm/cm3</b>	<b>gasket</b>	<b>needle cage</b>	<b>oil seal magn</b>	<b>oil seal.</b>
Charger, Mustang 488 1971; Voyager 488 1971; Colt 250 1972-78; Custom 2 1971; TC 250 1974-75;						
Electra 250 1975-77; Gemini 244 1979-83; Star 1983-90; Startrak 1987-90; Starlite Gt 1991-95						
<b>09-700</b>	72,00	<b>488 2-syl</b>	710-069	35-520	09-14102	09-14102
<b>09-700-02</b>	72,50	<b>244 1-syl</b>				
<b>09-700-04</b>	73,00					
Colt 250 1976-78						
<b>09-702</b>	53,50	<b>250 1-syl</b>	710-070	35-520	09-14103	09-14102
Starfire 250 1976; TX 250 1976-79						
<b>09-703</b>	53,40	<b>250 1-syl</b>		35-520	09-14103	09-14102
TX 440 1973; Electra 440 1974-77; Cobra 440 1978-79; Galaxy 440 1980-81; Cutlass 440, E 1981-82;						
TX-C 440C 1981; Long Track 1983-86; Sport, Super Sport SS 1983						
<b>09-704</b>	67,72	<b>432 2-syl</b>	710-078	35-520		
<b>09-704-02</b>	68,22				09-14102	09-14102
TX 440 1976-80						
<b>09-705</b>	67,75	<b>440 2-syl</b>	710-079	35-520	09-140	09-140
Starfire 340. 1976, TX 340 F/A 1973-82						
<b>09-706-01</b>	62,00	<b>336 2-syl</b>	<b>710-075</b>	35-513		
Indy 400 1984-1991; Indy 600 1984-87						
<b>09-707</b>	65,00	<b>398 2-syl</b>	<b>710-109C</b>	35-503	09-14102	09-14102
<b>09-707-01</b>	65,25					
<b>09-707-02</b>	65,50	<b>597 3-syl</b>	710-110			
<b>09-707-04</b>	66,00					
Colt SS 340 1977; Cobra 340 1978-79; SS 340 1979; Apollo, Galaxy, Cutlass 340 1979-1981						
<b>09-708</b>	61,78	<b>333 2-syl</b>	710-073	35-513	09-14102	09-14102
<b>09-708-02</b>	62,28					
Sprint ES 1986-90; Indy Sport, GT 1987-90; Indy Lite, GT, Starlite 1991-93						
<b>09-709</b>	62,25	<b>339 2-syl</b>	710-173	35-525	09-14102	09-14102
<b>09-709-01</b>	62,50					
<b>09-709-02</b>	62,75					
<b>09-709-04</b>	63,25					
TXC 440 FC 1982; Indy Trail 1983-1986; Long Track 1984-90; Indy Sport 1991-98; Sport GT 1991-93						
Sport Touring 1995-98; Super Sport 1995-96; Transport 1996-98						
<b>09-710</b>	67,75	<b>440 2-syl</b>	710-186	35-503	09-14102	09-14102
<b>09-710-02</b>	68,25					
<b>09-710-04</b>	68,75					
Indy 500 LC, Classic 1989-00; Indy 500, SKS, SP, 1990-98; Indy 500 EFI 1992-98						
Indy Classic Touring 1993-94; Indy Widetrack 1997-98						
<b>09-711</b>	72,00	<b>488 2-syl</b>	710-185A	35-503	09-14102	09-14102
<b>09-711-01</b>	72,25					
<b>09-711-02</b>	72,50					
<b>09-711-04</b>	73,00		<b>MOS 2 surface</b>			
<b>09-711-06</b>	73,50		<b>59</b>			

Polaris	dia mm	ccm/cm3	tiivistesarja	neulalaakeri	tiiviste .magn	tiiv.kytkin
Indy Trail FC 1986; Indy Tr. DeLuxe 1988-92; Super Sport 1997-98; Supertrac 1991-93; Indy Trail, Touring 1994-99						
<b>09-712</b>	72,00	<b>488 2-syl</b>	710-110C	35-503	09-14202	09-14202
<b>09-712-01</b>	72,25					
<b>09-712-02</b>	72,50					
<b>09-712-04</b>	73,00					
Indy 650, SKS 1988-93; Indy 650, RXL, SKS, 1990-97						
<b>09-713</b>	67,75	<b>648 3-syl</b>	710-181A	35-503	09-14202	09-14104
<b>09-713-01</b>	68,00					
<b>09-713-02</b>	68,25					
<b>09-713-04</b>	68,75					
Indy 580 XLT, SKS, XLT SP 1993-94						
<b>09-714</b>	64,00	<b>579 3-syl</b>	710-191	35-525	09-14202	09-14202
<b>09-714-01</b>	64,25					
<b>09-714-02</b>	64,50					
<b>09-714-04</b>	65,00					
Indy 440 XC 1992; Indy 440 XCR 1993-94; Indy Trail DeLuxe 1993						
<b>09-715</b>	67,72	<b>440 2-syl</b>		35-503	09-14202	09-14202
<b>09-715-01</b>	67,97					
<b>09-715-02</b>	68,22					
Indy XLT 600 1995-98; XLT SP 1997-98; Indy XCR 600 1995-97; XC 600 1997						
<b>09-716</b>	65,00	<b>597 3-syl</b>	710-205, 95-00	35-525	09-14202	09-14202
<b>09-716-01</b>	65,25					
<b>09-716-02</b>	65,50		710-204, 94-97			
Indy Lite, DeLuxe; Indy Lite Gt 1994-98; Indy Lite Touring 1998						
<b>09-717</b>	62,30	<b>340 2-syl</b>		35-525	09-14202	09-14202
<b>09-717-01</b>	62,55		<b>MOS 2 pinnoite</b>			
<b>09-717-02</b>	62,80					
<b>09-717-04</b>	65,50					
Indy Ultra SP, Ultra SPX, SE, Ultra Touring 1996-97						
<b>09-718</b>	66,50	<b>679 3-syl</b>	710-206	35-503		
Indy Storm 800 1994-98						
<b>09-719</b>	72,00	<b>794 3-syl</b>		35-503		
RMK 500, SKS 2000-02, 500 XC1999-02, Indy500 99, Indy 500 XC SP 1999-07, Indy 500 2001						
<b>09-720</b>	70,50	<b>500 2-syl</b>				
<b>09-720-02</b>	71,00					
Indy 550 Classic, Sport Touring, Supersport 1999-2006, Pro X Fan,						
<b>09-727</b>	73,0	<b>550 2-syl</b>	710-238	35-503		
<b>09-727-01</b>	73,25					
<b>09-727-02</b>	73.50					
<b>09-727-04</b>	74,00					
Indy 600 Classic, Touring 2001, Indy 600 Touring 2000, 600 XC SP, Edge 2000, 600 XC SP 2001						
<b>09-728</b>	77,25	<b>600 2-syl</b>				
Indy 800 XC SP 2001-05, 800 SKS 2003, 800 Classic 2004, 800 LE 2001, 800 Pro X 2003-04, 800 Edge 04						
<b>09-730</b>	85,00	<b>800 2-syl</b>		35-526		

# Yamaha Pistons Gaskets Needle cage Oil seals

YAMAHA	dia mm	ccm/cm3	gasket	needle cage	oil seal magn	oil seal
Br 250 1982-94 Br 250T, TS 1985-00; BR 250 TS 1984-97						
<b>09-800</b>	70,00	<b>246 1-syl</b>	710-027	35-505	09-131	09-132
<b>09-800-01</b>	70,25					
<b>09-800-02</b>	70,50					
ET 250 1977-81						
<b>09-801</b>	72,96	<b>246 1-syl</b>	710-138	35-522	09-131	09-132
<b>09-801-01</b>	73,21					
<b>09-801-02</b>	73,46					
<b>09-801-04</b>	73,96					
EC 340 1982-88 ET 340 1978-88 CS 340 1989-00						
<b>09-802</b>	60,00	<b>337 2-syl</b>	710-142	35-522	09-131	09-132
<b>09-802-01</b>	60,25					
<b>09-802-02</b>	60,50					
<b>09-802-04</b>	61,00					
GP 338 1973 SL 338 1974 GS 338, 340 1976-1979						
<b>09-803</b>	60,00	<b>338 2-syl</b>		35-505	09-135	09-143
<b>09-803-02</b>	60,50					
<b>09-803-04</b>	61,00					
EX 340 1976-78 STX 340 1976-1977						
<b>09-804</b>	60,00	<b>338 2-syl</b>	710-141	35-505	09-137	09-143
<b>09-804-02</b>	60,50					
GP; TL, 433 1975 EX 440 1976-81 GP 440 1976-78 PR 440 1976-77 STX 1976-77						
<b>09-806</b>	68,00	<b>433 2-syl</b>	<b>Katso tiiviste</b>	35-505	09-137	09-143
<b>09-806-01</b>	68,25		<b>kelkkakohtaisesta</b>			
<b>09-806-02</b>	68,75		<b>luettelosta</b>			
<b>09-806-04</b>	69,00					
SS 440 1980-83						
<b>09-807</b>	66,00	<b>440 2-syl</b>	710-147C	35-505	09-137	09-143
<b>09-807-02</b>	66,50					
EC 440 1979-84 SR 540 1980-91 XL 540 1985-90 VK 540 1988-00						
<b>09-808</b>	73,00	<b>535 2-syl</b>				
<b>09-808-01</b>	73,25					
<b>09-808-02</b>	73,50					
<b>09-808-04</b>	74,00					
SL 292 1971-72						
<b>09-810-02</b>	73,50	<b>292 1-syl</b>		35-505		
ET 300 1980-84						
<b>09-811</b>	56,00	<b>294 2-syl</b>	710-138A	09-505	09-135	09-143
<b>09-811-02</b>	56,50					
GP 292 1972-73 SM 292 1973-74						
<b>09-812</b>	73,00	<b>292 1-syl</b>		35-505		
<b>09-812-02</b>	73,50					

**See the seal [www.teolehtimaki.fi](http://www.teolehtimaki.fi) list. That the case of the piston is always the case for many years, and the seal may change to some model. In addition, please note, all the sleds are not necessarily listed on this page.**

# Yamaha Pistons Gaskets Needle cage Oil seals

YAMAHA	dia mm	ccm/cm3	gasket	needle cage	oil seal magn	oil seal
PZ 480 1984-98 480 ST 1991-98 VT 480 1991-97 VT 480 GT 1993-9 VT 480 TF/X 1993-00						
PZ 500 1999-00; PZ 500 ML 2000 PZ Mtn 480 1999 Venture 500 1999-06						
<b>09-813</b>	72,00	<b>485 2-syl</b>	710-168	35-505	09-14303	09-14302
<b>09-813-01</b>	72,25		<b>Katso tiiviste</b>			
<b>09-813-02</b>	72,50		<b>kelkkakohtaisesta</b>			
<b>09-813-04</b>	73,00		<b>luettelosta</b>			
SR 433, GPX 433 1971-75						
<b>09-814</b>	68,00	<b>433 2-syl</b>		35-505	09-137	09-143
<b>09-814-01</b>	68,25					
<b>09-814-02</b>	68,50					
<b>09-814-04</b>	69,00	<b>433 2-syl</b>		35-505		
GPX 338 F/A 1974-75						
<b>09-815</b>	60,00	<b>338 2-syl</b>		35-505	09-137	09-143
<b>09-815-01</b>	60,25					
<b>09-815-02</b>	60,50					
VMX 540 1983-91						
<b>09-816</b>	73,00	<b>535 2-syl</b>	710-140A	35-521		
Exciter 570, 1987-90 Exciter 2, 1991-92						
<b>09-817</b>	73,00	<b>569 2-syl</b>	710-171	35-521	09-14313	09-14301
<b>09-817-02</b>	73,50		710-171A			
<b>09-817-04</b>	74,00		<b>MOS 2 surface</b>			
SRX 440 1978-1980						
<b>09-818</b>	68,50	<b>439 2-syl</b>	710-147A	35-512	09-137	09-143
<b>09-818-01</b>	68,75					
<b>09-818-02</b>	69,00					
V-Max 500 LE, DX, ST, 1994-96						
<b>09-825</b>	68,00	<b>493 2-syl</b>	710-200	35-521		
V-Max 600, LE, DX, ST, 1994-96						
<b>09-826</b>	74,80	<b>598 2-syl</b>	710-201	35-521		
<b>09-826-02</b>	75,30					

# Kohler, Sachs, Kawasaki Pistons Gaskets Needle cage Oil seals

Kohler	dia mm	ccm/cm3	gasket	needle cage	oil seal magn	oil seal
<b>Kohler 340 moottori</b>						
<b>09-670</b>	62,00	<b>340 2-syl</b>		35-520	09-104	09-113
<b>09-670-01</b>	62,25					
<b>09-670-02</b>	62,50					
<b>09-670-04</b>	63,00					
<b>Sachs</b>						
<b>Sachs 440</b>						
<b>09-SM127</b>	67,40	<b>436 2-syl</b>			09-116	09-127
<b>Kawasaki</b>						
Kawasaki 440 Kawasaki Intriguer, Intruder, Invader; Drifter 440 1978-81						
<b>09-689</b>	68,00	<b>440 2-syl</b>		35-522	09-14603	09-14603
Invader 340 F/C 1978-80, Inviter 340 F/C 1978, Drifter F/C 1979-81						
<b>09-685</b>	60,00	<b>339 2-syl</b>	<b>62</b>	35-525		

# Windshields

**Note: always measure the height of the windshield from the light opening along the surface.**

00-110	5 393 062	GL 250 - >88
00-111	524090X	GL 250 S, GL 230 89->91
00-112	526754	GL 360 S 92->95
00-115		539504 Forest Fox 96->98, 01
00-120	522842X	GL 3900, GLX 5900 steel brackets->93
00-121	538284-1	GLX 5900, with screws 1995
00-122	523192X	GLS 3300 low
00-123	538616	GLX 5900, 1995
00-130	524126X	GL 3300, GL 3900 S, 88->92
00-133	538837	COBRA 94->95, ULTRA 94->96
00-140	5393890-1	640
00-141	6500202-2	650 with screws 1995
00-142	533084X	650 steel bracket 83->94
00-151	537644	RANGER, LIGHT, GT 93->97
00-181	5241686	GLX 5900 96->99, 6900 1997
00-300	Nordik 300	
00-377	Nordik 377 R	
00-500	Nordik 500, 600, 7 slots	
00-510	Trapper, 5000, 5 slots	
00-550	Nordik 550	

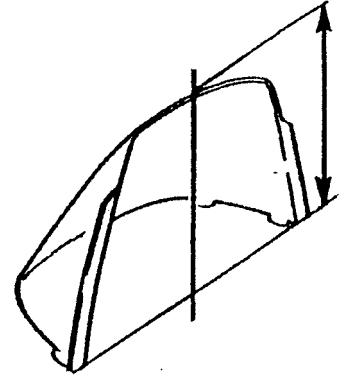

Original production.



**12-165 Mirror**

# Vintage models



37-08



41-40

**37-08 Ockelbo rubber spring**



**00-600 Lynx decals 1969-75**

**00-601 Head, decal, whit. 1969-75**

**00-602 Team Lynx ecal, -80 cent.**

**41-40 Rear spring Lynx 40, 30, 20**

**41-535 Spring, wheel boogie Lynx**

# Brake pads

## Arctic Cat

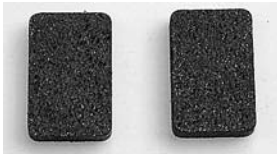

**05-15225 pair**  
AC 0109-932



**05-15232 pair**  
AC 0115-603



**05-15240 pair**  
AC 0702-264

## Polaris



**05-15241 pair**  
AC 0702-229

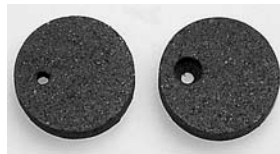

**05-15203 pair**  
Pol 193034/5



**05-15214 pc**  
Pol 1930 569



**05-15231 pc**  
Pol 1930 588



**05-15237 pc**  
Pol 1930 586



**05-15243 pair**  
Pol 1930 723

## Ski-Doo Lynx

## Nordik



**05-15212 pair**  
Sk 860.701.400

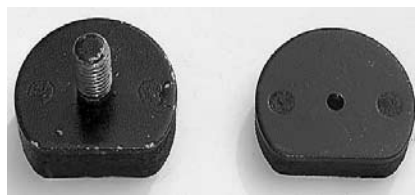

**05-15235 pair**  
Skidoo, Lynx, Nordik



**05-15247 pair**  
Sk 860.701.700



**05-15241 pc**  
Sk 414.933.700  
Lynx

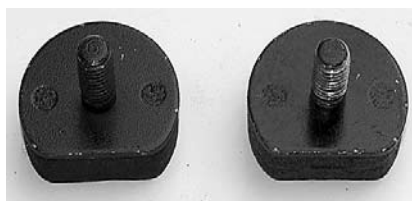

**05-15242 pair**  
Sk 860.700.700  
Lynx



**05-15246 pc**  
Sk 414.990.000  
Lynx

# Brake pads Yamaha



**05-15224 pair**



**05-15228 pc**



**05-15245 pc**



**05-15249 pair**

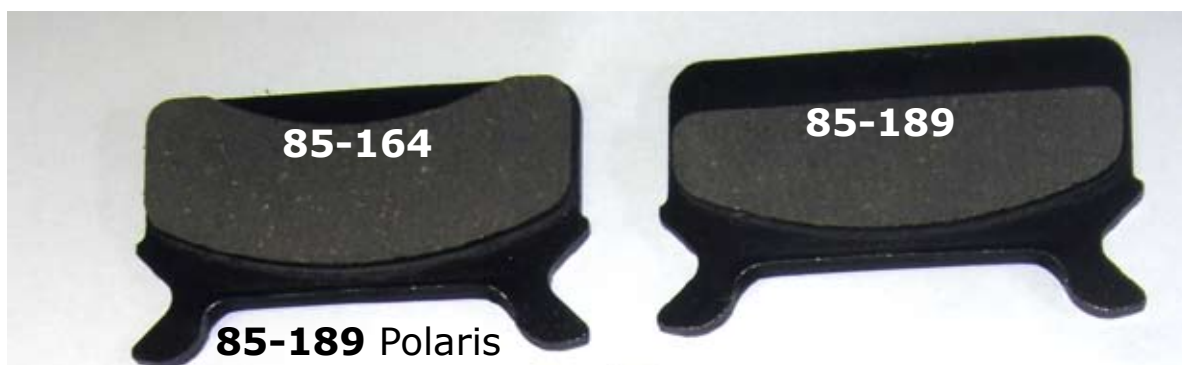

**85-164**

**85-189**

**85-189**  
Polaris  
Widetrack  
1997-2005

**85-189** Polaris  
Widetrack 99-2003



**85-200**



**85-188**

**85-200** Skidoo  
Mxz 500 2003  
Legend 2002

**85-188** Polaris  
2003-2009



**85-184**



**85-167**

**85-184** Lynx  
86-1993

**85-167** Polaris  
Supertrack 1992  
Widetrack 91-93



**85-183**



**85-179**



**85-162**

**85-183** Lynx 535,  
GL3900 84-86  
650 ja 5900- 84

**85-179** Ockelbo

**85-162** Lynx 535,  
3900 84-87  
Lynx5900, 650 89-90

# Chain specifications

( Silent, Hyvo, DID )

Pict	Prod	Plates	Plate stack	ID Stamp	Manufacture	Note.
1	<b>45-</b>	11	1-2-1-1-1-1-1-2-1	LB S37 U.S.A	Rexnord	Silent 11
2	<b>46-</b>	13	1-2-1-1-1-1-1-1-1-2-1	LB S37 U.S.A	Rexnord	Silent 13
3	<b>50-</b>	15	1-2-2-2-1-2-2-2-1	LB S37 U.S.A	Rexnord	Silent 15
4	ei	13	1-1-1-1 ( x 13 )	DID	D.I.D	
5	ei	15	1-1-1-1 ( x 15 )	DID	D.I.D	
8	ei	15	??	Morse	Borg Warner	Hyvo 7/8
7	<b>52-</b>	13	1-2-1-1-1-1-1-1-1-2-1	Morse	Borg Warner	Hyvo 3/4

Rexnord

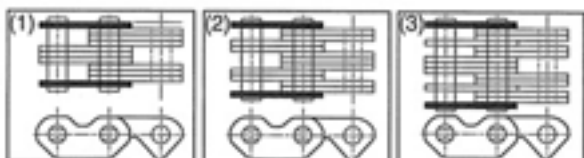

Images show the old plates stacking, but these are the current and can be used, as long as the stamp is the same. It is the most common chain model. **Silent**

Borg Warner

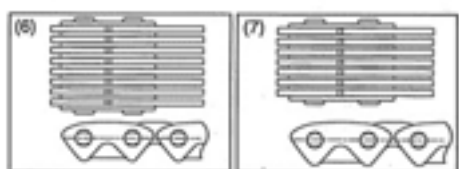

Images show the old plates stacking, but these are the current and can be used, as long as the stamp is the same. trade name, **Hyvo 3/4**

D.I.D.

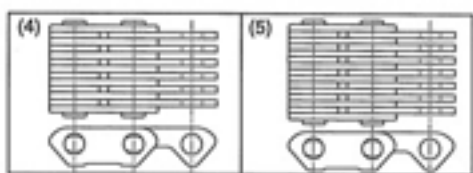

DID chain is used Yamaha in the 1990s. rare model.

## Lower gears, Skidoo, Lynx

13 wide	Z	13 wide	Z	15 wide	Z	15 wide	Z
steel		aluminium		steel		aluminium	
<b>55-43</b>	<b>43</b>	<b>56-43</b>	<b>43</b>	<b>58-43</b>	<b>43</b>	<b>60-43</b>	<b>43</b>
<b>55-44</b>	<b>44</b>						
<b>55-45</b>	<b>45</b>	<b>56-45</b>	<b>45</b>	<b>58-45</b>	<b>45</b>	<b>60-45</b>	<b>45</b>

## Sprockets, 7/8"-13 spline

Arctic Cat all, not Diamond drive, Polaris up to 1996

11-wide	Z	11-wide	Z	13-wide	Z	13-wide	Z
<b>47-016</b>	<b>16</b>	<b>47-021</b>	<b>21</b>	<b>48-016</b>	<b>16</b>	<b>48-021</b>	<b>21</b>
<b>47-017</b>	<b>17</b>	<b>47-022</b>	<b>22</b>	<b>48-017</b>	<b>17</b>	<b>48-022</b>	<b>22</b>
<b>47-018</b>	<b>18</b>	<b>47-023</b>	<b>23</b>	<b>48-018</b>	<b>18</b>	<b>48-023</b>	<b>23</b>
<b>47-019</b>	<b>19</b>	<b>47-024</b>	<b>24</b>	<b>48-019</b>	<b>19</b>	<b>48-024</b>	<b>24</b>
<b>47-020</b>	<b>20</b>			<b>48-020</b>	<b>20</b>		

# Silent chain

11 wide	length	13 wide	length	15 wide	length
45-064	64	46-064	64	50-064	64
45-066	66	46-066	66	50-066	66
45-068	68	46-068	68	50-068	68
45-070	70	46-070	70	50-070	70
45-072	72	46-072	72	50-072	72
45-074	74	46-074	74	50-074	74
45-090	90	46-076	76	50-076	76
		46-104	104	50-078	78
		46-106	106		
		46-108	108		



## 3/4" Hyvo chain

Original Borg Warner chain

3/4" width	length		3/4" width	length
52-66	66		52-80	80
52-68	68		52-82	82
52-70	70		52-86	86
52-72	72		52-90	90
52-74	74		52-92	92
52-76	76		52-94	94
52-78	78			

## Sprockets, Skidoo, Lynx

11 wide	Z	13 wide	Z	15 wide	Z
45-016	16	46-016	16		
45-017	17	46-017	17		
45-018	18	46-018	18		
45-019	19	46-019	19	50-019	19
45-020	20	46-020	20	50-020	20
45-021	21	46-021	21	50-021	21
45-022	22	46-022	22	50-022	22
45-023	23	46-023	23	50-023	23
45-024	24	46-024	24	50-024	24
		46-025	25	50-025	25
		46-026	26		



# CDI-Boxes



**01-14342**  
Rotax 410.918.900



**01-14343**  
Rotax 420.965.591



**01-401**  
Arctic Cat 3004-099



**01-14340**  
Rotax 420.866.595



**01-415**  
Yamaha 8V0.85540.21



**01-407**  
Polaris 3083725



**01-14345**  
Rotax 420.965.757



**01-40701**  
Polaris 3083989



**01-40801**  
Polaris 3084007



**01-14329**  
Arctic Cat 3003-777



**01-14372**  
Skidoo 512.058.927 Form.

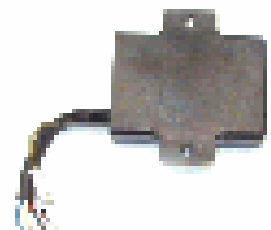

**01-406**  
Pol. 3083721 600-650



**01-404**  
Polaris 308 3723



**01-14327**  
Arctic Cat



**01-14332**  
Bosch, Skidoo, Motoski

# Ignition coils



**01-14310**  
Rotax 410.916.000



**01-14311**  
Rotax 410.913.500 Arctic



**01-14319**



**01-14312**  
Arctic Cat 3003-221



**01-14313**  
Polaris 3082974



**01-143120**  
Arctic Cat 3003-977



**01-14314**  
Yamaha 8W3.82310.10



**01-14315**  
Yamaha 8E7.82310.10



**01-14317**  
Yamaha 5.82310.40



**01-14351**  
Yamaha 8AB.82310.10



**01-14353**  
Arctic Cat 3003-575



**01-14355**  
Rotax 10.920.500



**01-14350**  
Yamaha Bravo 250 -88



**01-14363**  
AC 3005-381 ZL-ZR 5-700



**01-14371**  
Rotax 420.996.705  
Form. III, Mach1, Z, ZR

## Ignition coils



**01-14360**  
Arctic Cat 3004-126



**01-14361**  
Arctic Cat 3004-483



**01-14362**  
Polaris 3084469

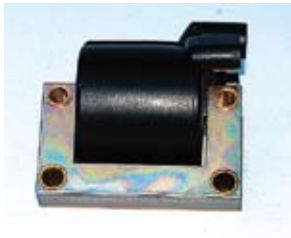

**01-1430**  
Rotax, Bosch, Arctic Cat



**01-14367**  
Polaris 3085293



**01-14370**  
Formula 415.085.400

## Safety stop swith



**01-113** Arctic Cat



**01-11120**  
Skidoo



**01-11113**  
Yamaha, Arctic Cat, Polaris



**01-112**



**01-120**  
Universal, oldies  
Push-stop-model



**BOSCH**

**05-B8** BR8ES resistor type  
**05-B9** BR9ES resistor type

# Voltage regulator

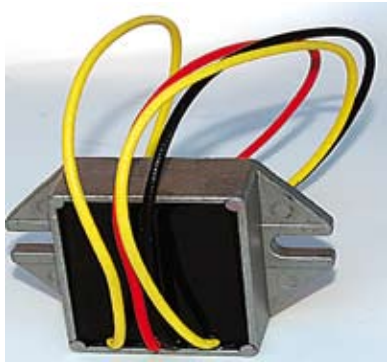

**01-15416**      **3 wires**  
**01-15416B**    **4 wires**



**01-15402**  
 Rotax 410.908.900



**01-15406**  
 Rotax, Arctic Cat



**01-15417**      **250 W**  
 Tasasuuntaaja Rotax



**01-15415**  
 Rotax 410.908.900



**01-15421**  
 Polaris 4060122



**01-15418**  
 Tasasuuntaaja Arctic Cat



**01-15426**  
 Arctic Cat 0232-014



**01-15432**  
 Yamaha 82F.81910.



**01-15435**  
 Yamaha 82M.81910.AO



**01-15436**  
 Yamaha 98A.81910.00

# Spark plug cap



**01-110**



**01-1011**

# Starters



## 01-0912 Polaris

Polaris: 417 0006  
 Artco: 0645-184  
 1997-2007



## 01-0201 Arctic Cat

Artco: 0745-018  
 -030,-052,-257  
 1991-2007



## 01-0202 Arctic Cat

Artco: 0645-183  
 -312,  
 1995-2002



## 01-0203 Arctic Cat

Artco: 0745-143  
 -126,-356  
 2001-2007



## 01-0204 Skidoo

BRP: 515-175-562  
 515-175-843  
 515-176-003  
 2000-2007



## 01-0228 Kubota

Kubota: 70000-65440  
 Denso: 228000-6910  
 Denso: 228000-6911



## 01-0206 Yamaha

Yamaha:  
 8BB- 81800-01-00  
 1994-2005



## 01-0207 Yamaha

Yamaha:  
 8CW- 81800-00-00  
 8CW-81800-01-00  
 19947-2005



## 01-0229 Denso

Denso: 228000-1670  
 Denso: 228000-1671  
 BRP: 410-207-500

# Starters

01-0192		<b>DG-0058-1</b> 9-tooth Drive gear 	<b>CB-0092-10</b> Brush holder Assembly 	Repl: UT 5698340; Polaris 4170006
01-0201		<b>DG-0058-1</b> 9-tooth Drive gear 	<b>CB-0092</b> Brush holder Assembly 	Repl: ARCTCO 0745-018, -030, -052, -257
01-0202			<b>CB-0092-1</b> Brush holder Assembly 	Repl: ARCTCO 0645-183, 0645-312
01-0203			<b>CB-0092-10</b> Brush holder Assembly 	Repl: ARCTCO0745-143
01-0204		<b>DG-0091-1</b> 8-tooth Drive gear 	<b>CB-0210</b> Brush holder Assembly 	Repl: 428000-1101, -3530; Ski-Doo 515-175-562, -843, 515-176-003, -133
01-0205		BRP: 410-212-400		Repl: Bombardier 410-212-400
01-0206		<b>DG-0092-1</b> 9-tooth Drive gear 	<b>CB-0063</b> Brush holder assembly 	Repl: Yamaha 8BB-81800-01-00
01-0207		<b>DG-0093-1</b> 9-tooth Drive gear 	<b>CB-0140-1</b> Brush holder Assembly 	Repl: Yamaha 8CW-81800-00-00, 8CW-81800-01-00
01-0228		<b>DG-0095-1</b> 9-tooth Drive gear 	<b>CB-0140-1</b> Brush holder Assembly 	Repl: Kubota 70000-65440
01-0229		<b>DG-0095-1</b> 9-tooth Drive gear 	<b>CB-0140-1</b> Brush holder Assembly 	Repl: Denso128000-1670, 128000-1671

	PROPELLERS	HP	DIAMETER/PITCH
YAMAHA	6F8-45942-00-36	2	7 1/4*5-A
	683-45943-00-EL	9,9	9 1/4*10 1/2 J
	683-45945-00-36	9,9	9 1/4*9 J
	683-45952-00-EL	9,9	9 1/4*9 3/4 J
	626-45943-02-36	9.9/15	9 1/4*10 3/4 D
	626-45949-01-36	9.9/15	9 1/4*9 D
	648-45941-01-EL	25	9 1/2*11 1/2 D
	664-45945-00-EL	25/30	9 7/8*10 1/2F
	664-45949-02-EL	25/30	9 7/8*13F
	676-45941-62-EL	40	11 1/2*11 H
	676-45943-62-EL	40	11 1/2*12H
	676-45945-62-EL	40	11 3/4*10H
	676-45956-61-EL	40	11 3/4*7 1/2H
	663-45945-02-EL	48/55	11 1/8*13G
	663-45947-02-EL	48/55	11 5/8*11G
	663-45952-02-EL	48/55	11 3/8*12G
	663-45956-01-EL	48/55	12 1/4*9G
	663-45947-02-EL (S)	48/55	11 5/8*11G
	6E5-45945-01-EL	75/85/115/140	13 1/4*17K
6E5-45947-00-EL	75/85/115/140	13 1/2*15K	
6E5-45949-00-EL	75/85/115/140	13 5/8*13K	
6E5-45947-00-EL (S)	75/85/115/140	13 1/2*15K	
6G5-45978-03-98	(S)150/200	13 3/4*17-M27	
6G5-45974-03-98	(S)150/200	13 3/4*19-M2	
XL700	65R-R1321-10	80hp	
SUZUKI	58111-98452-019	□ 2	188*122
	58111-98452-010	□ 2	188*122
	58100-93763-019	□ 15	9 1/4*9
	58100-93723-019	□ 15	9 1/4*9
	58100-93743-019	□ 15	9 1/4*11
	58110-96331-019	□ 20/30	10 1/4*12
	58100-96430-019	□ 20/30	10 1/4*12
	58100-94313-019	□ 40	11 1/2*13
	58100-95353-019	□ 40	11 3/8*14
	8100-95393-019	40	11 5/8*12

PROPELLERS	HP	DIAMETER/PITCH
JOHNSON 391199 □	65/90	13 1/4*17
TOHATSU 362-64101-00 353-64104-00	9.9/15 60/70	9,0 12
MERCURY 48-168999 (S)	60	10 1/8*15P



663-45947  
-02-EL



663-45952  
-02-EL



683-45943  
-00-EL



6E5-45945  
-01-EL



6E5-45947  
-00-EL



626-45943  
-02-36



626-45949  
-01-36



663-45945  
-02-EL



58100-  
94313-019



58111-  
98452-010

## Impellers



663-11411-01



47-89984



6F5-44352-00



396809



6E5-44352-00



6G5-44352-00

# Flip, instruction

## Pictures:

In the pictures, you can see mounting of a **384** cm long track.

In order to achieve the best possible track alignment, mount the shaft as far to the left as possible

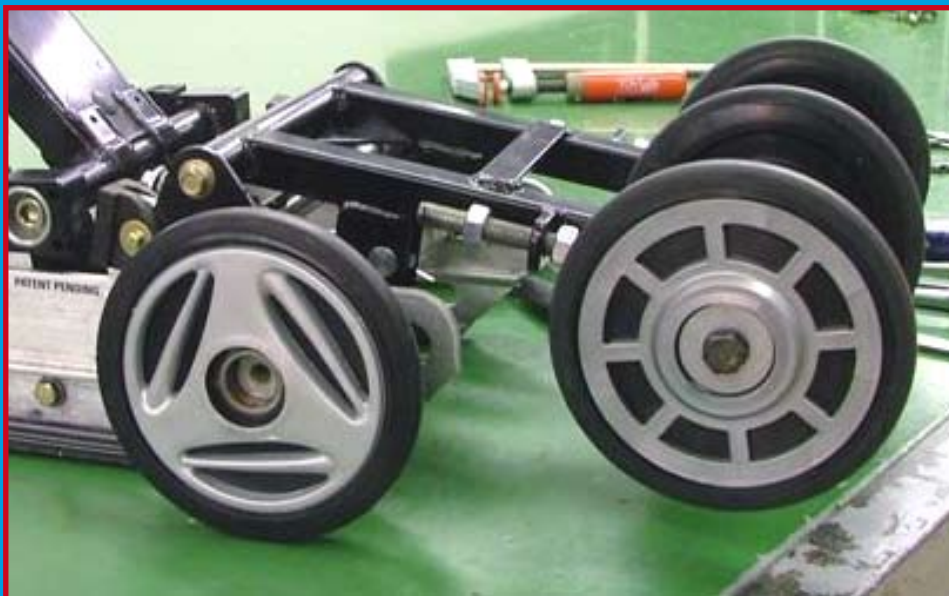

## Pictures:

In the pictures, you can see mounting of a **403** cm long track.

In order to achieve the best possible track alignment, mount the shaft as far to the left as possible



**La Famiglia Biaudet**  
**[www.allimperatore.com](http://www.allimperatore.com)**  
**[www.hotelpalu.com](http://www.hotelpalu.com)**  
**+39 0465 440858**  
**Madonna di Campiglio**  
**Italy**

